



HIGH FLOW WHOLE HOUSE WATER FILTER
PC1665-P

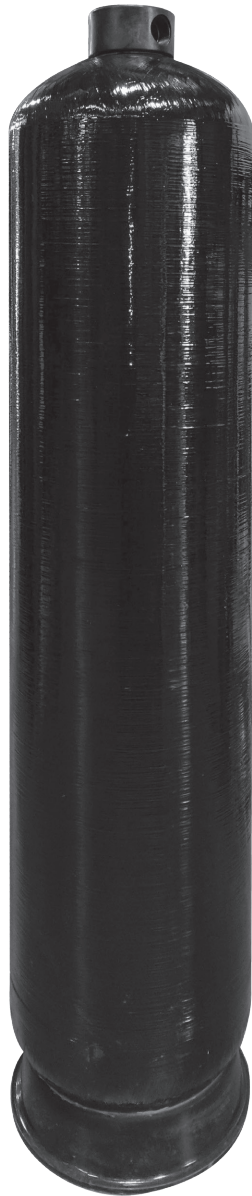

TABLE OF CONTENTS

IMPORTANT INFORMATION	2
CUSTOMER SERVICE CONTACT INFORMATION	2
PRODUCT OPERATION AND SPECIFICATIONS	3
COMPLETE PARTS LIST	3
INSTALLATION	
INSTALLATION OVERVIEW	4
CARBON TANK SOAK	5
CARBON TANK WASH	6
SEDIMENT FILTER INSTALLATION	7
CARBON WATER FILTER TANK INSTALLATION	8
COMPLETE THE INSTALLATION	9
MAINTENANCE	10
TROUBLESHOOTING	11
PRODUCT WARRANTY & REGISTRATION FORM	12
PRODUCT CERTIFICATIONS	13

IMPORTANT INFORMATION

- Read these instructions carefully and determine the location of all system components before beginning installation.
- Check all applicable plumbing, building, and electrical codes for installation compliance.
- Install the system on the main water supply.
- The use of plumbers tape and/or pipe thread seal paste will be needed on all threaded connections.
- To condition all water in the home, install the Carbon Water Filter System close to the water supply inlet, and upstream of all other plumbing connections, except outside water pipes. Outside faucets should remain on unfiltered water.
- Systems that contain electronic components cannot be installed outside in uncovered areas.

WARNING

Installing this system in a metal (conductive) plumbing system, i.e., copper or galvanized metal, will interrupt the continuity of the plumbing system and grounding source in some homes. If your home's electrical appliances are grounded through the plumbing system, you will need to install a bypass that consists of the same material as the existing plumbing or a grounded "jumper wire" to bridge the equipment and re-establish the contiguous conductive nature of the plumbing before using this Pentair system. Failure to do so can result in errant electricity from improperly grounded appliances or potential galvanic activity in the plumbing system, which could increase the risk of fire or injury while using your home appliances. Please consult a licensed electrician before attempting to install.

CAUTION

When adding a filtration/softening system to homes/buildings supplied by well water, the system should be installed following the pressure tank. **DO NOT USE this system for pneumatic or hydropneumatic applications. If you are using a booster pump, then install this system following the booster pump.** If you have questions, please call customer service.

Customer Service Contact Information Section

Homeowners Phone: 877.842.1635





Professionals Phone: 877.842.1635

PRODUCT OPERATION AND SPECIFICATIONS

Specification Description	PC1665-P
Rated Service Flow Rate	25 GPM
Minimum Working Pressure	25 PSI
Maximum Working Pressure	80 PSI
Maximum Vacuum	5 inch/127 mm Hg
Operating Temperatures	36°F - 120°F
pH Range	6 - 11

COMPLETE PARTS LIST

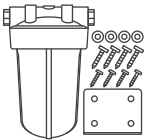
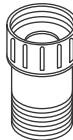
Note: The parts supplied are intended to accommodate a variety of water supply lines. Additional fittings may be needed to fit to your plumbing. Visit pentair.com to view our full line of installation kits.

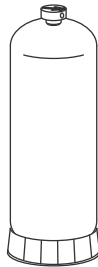
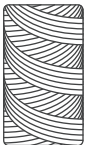
Part	Description	Qty.	Part	Description	Qty.
	PVC Adaptor: 1-1/2" to 1" Threaded PVC Adaptor Note: For Use with Tank Head	2		PVC Adaptor: 1" to 3/4" Threaded PVC Adaptor Note: For Use with Tank Head	2
	Prefilter System: Blue Filter Housing, Mounting Bracket, Phillips Head Screws (4), Bolt Head Screws (4), and Washers (4)	1		3/4" PVC Hose Bib	2
	Sediment Filter Spanner Wrench	1		Tank	1
	Sediment Filter: 5 Micron Polyspun Sediment Filter	1			

Note: Drawings are not to scale.
Additional fittings will be needed to adapt to your plumbing.

INSTALLATION OVERVIEW

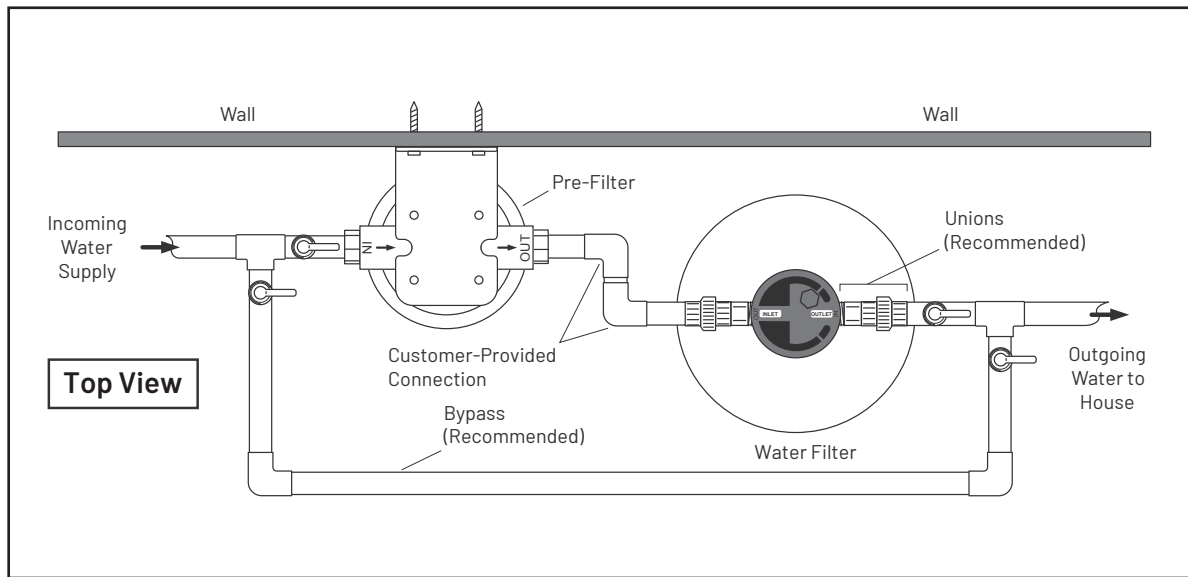

Note: The plumber should follow the stickers on the head.

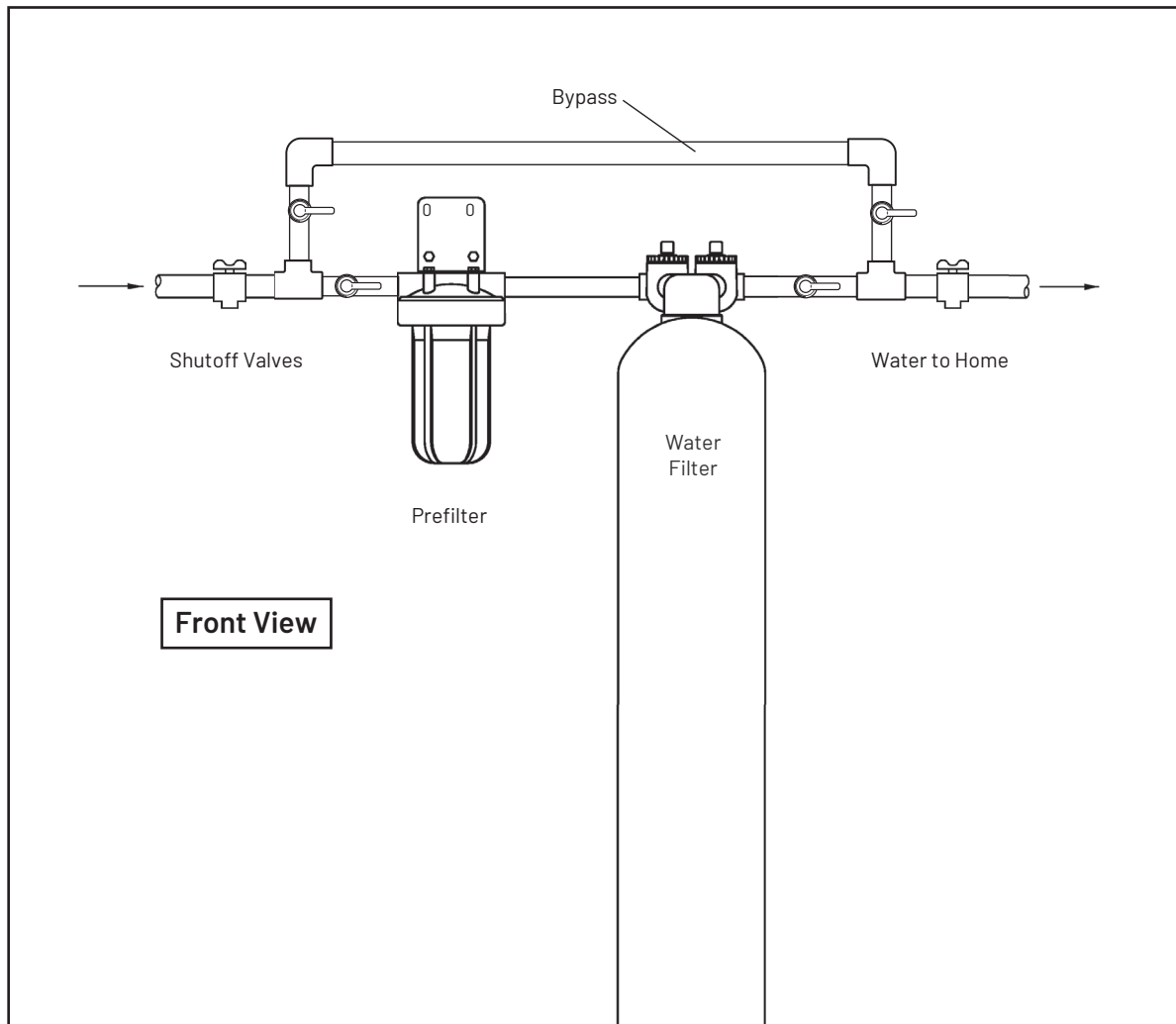

Note: Sediment filter position is at the discretion of your professional installer. As a general guideline, the sediment prefilter is typically installed in the "pre" position (as shown above) for well water applications. For city water applications, the sediment filter is typically installed in the "post" position after the Carbon Water Filter System.

CARBON TANK SOAK

Note: Your system will not be ready for use for a minimum of 48 hours while the Carbon Soak process takes place. Please plan your installation accordingly.



Notice

Water will flow out of the filter head during this process. Be sure you perform this series of steps in a location suitable for water flow.

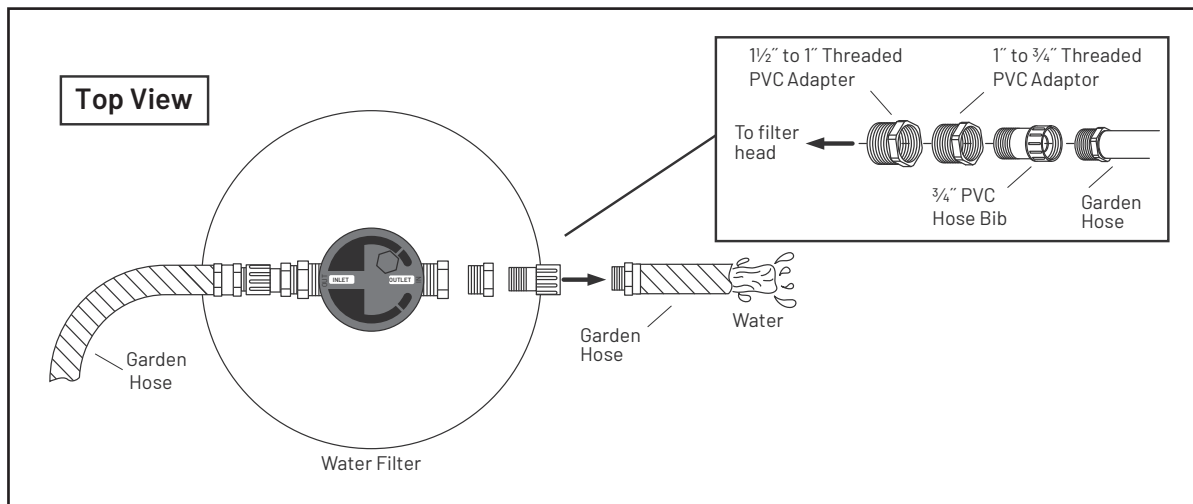

Carbon Tank Soak

Note: Steps 1-8 should be done prior to installation

1. Connect the 1-1/2" threaded PVC adapter to the inlet side of the tank head.
2. Connect the 1" threaded PVC adapter into the 1-1/2" adapter.
3. Connect the 3/4" PVC hose bib into the 1" adapter.
4. Connect your garden hose to the Hose bib adapter.
5. Repeat steps 1-4 on the Outlet side of the tank head.
6. Fill the Pentair Carbon Water Filter System tank full until water flows out of the second hose.
7. Turn the water off.
8. Allow the carbon tank to soak for at least 48 hours prior to tank installation.

CARBON TANK WASH

Note: Do not perform the Carbon Tank Wash until the Carbon Tank Soak process is complete.



Notice

Water will flow out of the filter head during this process. Be sure you perform this series of steps in a location suitable for water flow.

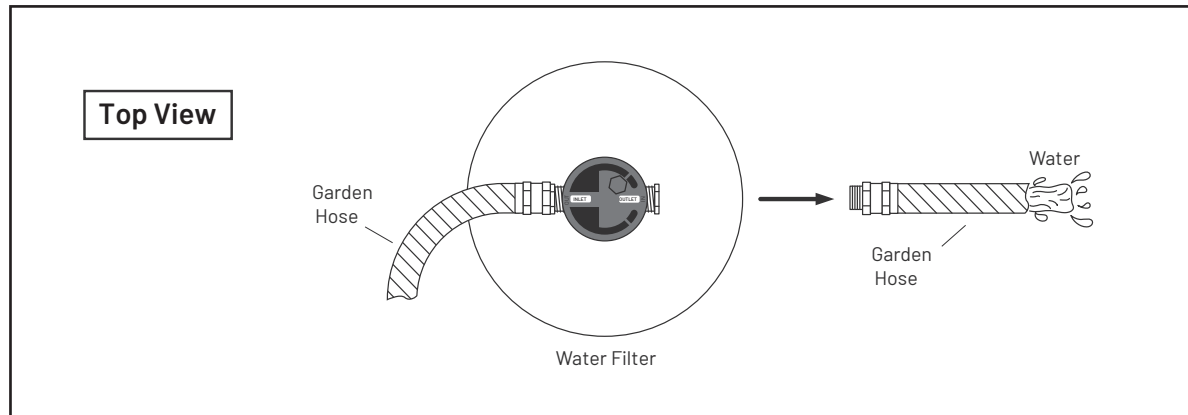

Carbon Tank Wash

1. Slowly turn on the water to the full position for this entire process.
2. Run water through the INLET side of the filter head for 60 minutes.
3. Turn off the water.
4. Remove the hoses and the hose bib adaptors.

SEDIMENT FILTER INSTALLATION

Note: Sediment filter position is at the discretion of your professional installer. As a general guideline, the sediment pre filter is typically installed in the "pre" position (as shown above) for well-water applications. For city water applications, the sediment filter is typically installed in the "post" position after the Water Softener Alternative tank.

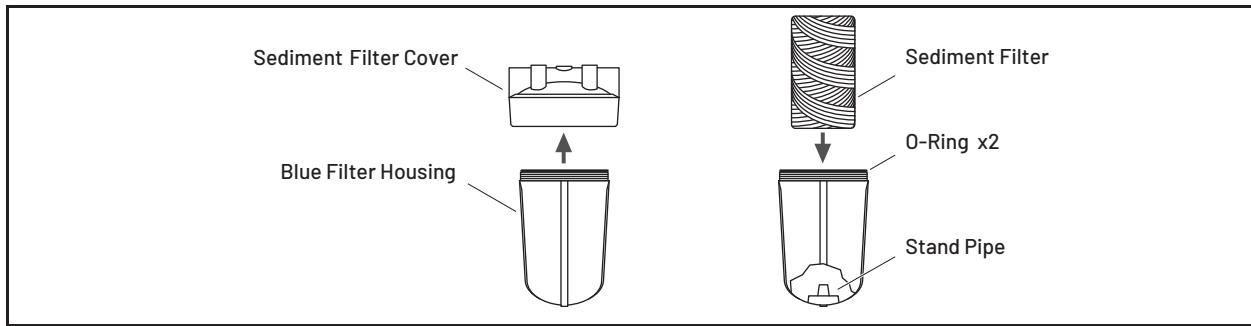

Part 1

1. Unscrew the cover from the blue filter housing.
2. Remove the plastic covering from the sediment filter.
3. Place the sediment filter onto the stand pipe in the blue filter housing and set aside.

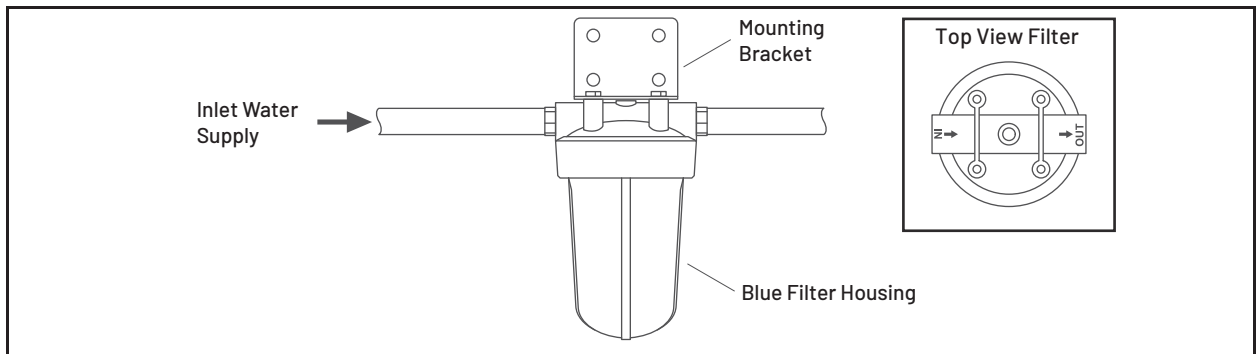

Part 2

1. Shut off the water.
2. Attach the filter cover to the mounting bracket using the supplied bolt head screws and washers. Make sure to properly orientate the IN and OUT to match your flow pattern.
3. Attach the mounting bracket to the wall using the supplied phillips head screws.
4. Hand tighten the blue filter housing and then, using the supplied filter wrench, lightly snug the housing making sure not to over-tighten (counterclockwise).
5. Determine the size of your inlet water supply line.



Notice

The Pre-Filter Housing comes with a 1/2" threaded female inlet/outlet and will require additional fittings to adapt to your plumbing. It is recommended that a shut-off valve and a bypass be plumbed in around the system before installing the Pre-Filter system.

CARBON WATER FILTER SYSTEM TANK INSTALLATION

1. Level the Carbon Water Filter System Tank.

Note: See "Troubleshooting" section on tips for leveling the tank.



Notice

If the tank is not level, lift the tank straight up six (6) inches and tap it on the ground until the tank stands vertically. The bottom of the tank is round and the boot allows the tank to stand upright.

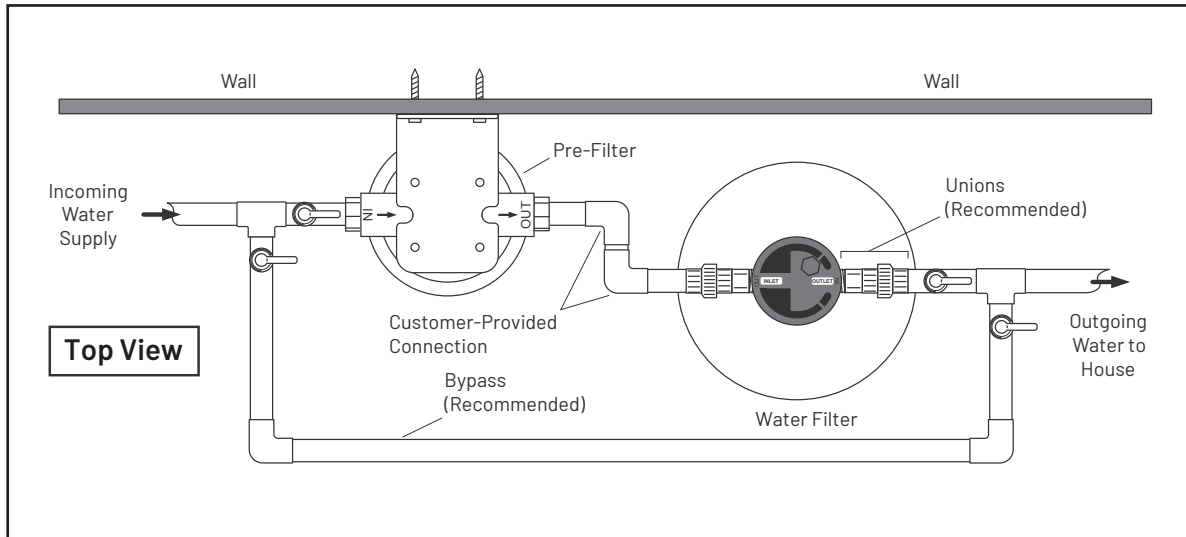

2. Determine the size and material of your incoming water supply line from the Carbon Water Filter and choose the appropriate fittings required to connect it to the filter head.



Caution

Do not over-tighten any of the fittings during installation.

Note: Visit pentair.com/homewater to view our full line of installation kits.

3. Install the fittings into the INLET and OUTLET sides of the filter.
4. Connect the incoming water supply from the sediment filter to the fitting on the INLET side of the filter.
5. Connect the outgoing water supply to the OUTLET side of the filter

COMPLETE THE INSTALLATION

1. Turn on the main water supply.
2. Check for leaks.



Caution

Avoid high flow rates such as bathtub, utility sinks, hose bibs, multi-headed showers, body sprayers, or anything that is considered high flow for the first 72 hours to avoid flow restrictions caused by carbon blockage of the top basket inside the carbon tank.



Caution

Carbon dust may be released into the water lines of the house/building during the first few days of water use after carbon tank installation. The carbon dust is harmless, but may give the water a gray appearance that should diminish within a week or 10 days depending on water use.

MAINTENANCE

Media Replacement

Your Pentair Whole House Water Filter requires care and cleaning after a period of 5 years. Replacement media and instructions can be ordered on-line at www.pentair.com/homewater or by calling 877-842-1635.

Sediment Filter

It is recommended that the sediment filter be replaced every 6-9 months depending on the amount of sediment present in the water supply. If the system has been working properly and the pressure is slowing, it may be time to change the sediment filter. Check the sediment filter and replace if necessary.

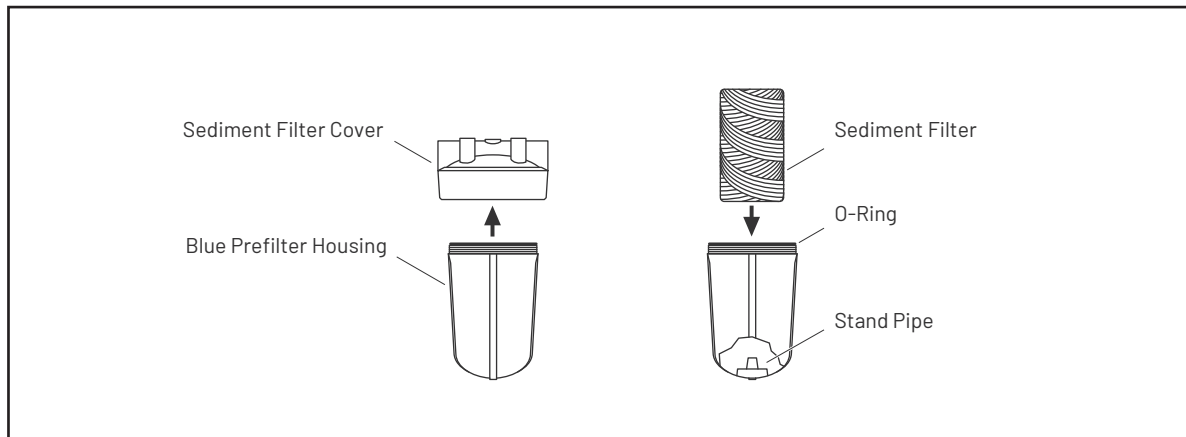

Replacing the Sediment Filter

1. Turn off the main water supply to the sediment filter system and bypass all tanks.
2. Run a faucet (cold water) inside the house to relieve the pressure. (leave the faucet open)
3. Unscrew the blue filter housing clockwise using the supplied filter wrench.
4. Remove the existing sediment filter and discard.
5. Remove the o-ring and wipe the upper groove clean. Lubricate the o-ring with a coating of clean silicone grease. Replace o-ring. Be sure to press the o-ring down into the groove with two fingers.

Note: This step is important to ensure the proper filter seal. Make sure the upper o-rings is seated level in the groove. If the o-ring appears damaged, stretched, or crimped it should be replaced.

6. Place a new sediment filter onto the stand pipe in the blue filter housing.
7. Screw the blue filter housing onto the filter cover hand tight. Lightly snug the housing with the spanner wrench making sure not to over-tighten.
8. Turn on the main water supply slowly to allow the sediment filter system to fill with water and expel air from lines. Put tanks back in service (out of bypass).
9. Check for leaks.

TROUBLESHOOTING

Problem	Solution
<p>Pressure is dropping off during the carbon wash.</p>	<p>Turn the water off and let the tank sit about 30 minutes to allow the carbon to settle down off of the basket inside the tank.</p> <p>If the pressure drops off again, let the system stand for 72 hours. There is air trapped in the carbon bed that needs to be released from the tank. After 72 hours have passed, continue the carbon wash by slowly turning the water supply back on.</p>
<p>Water leaking at the top of the tank around the head.</p>	<p>You may need to turn the head to tighten it. The tank head is preinstalled hand-tight, do not overtighten the head (simply turn it snug).</p>
<p>The tank leans to one side or is not level.</p>	<p>If the tank is not level, lift the tank straight up six (6) inches and tap it on the ground until the tank stands vertically. The bottom of the tank is round and the boot allows the tank to stand upright.</p>
<p>The diagrams illustrate the process of leveling the tank. The top row shows an unlevel tank with a dashed line representing the boot. An upward arrow indicates lifting the tank, and a downward arrow indicates tapping it. The bottom row shows an unlevel tank with a dashed line representing the boot. An upward arrow indicates lifting the tank, and a downward arrow indicates tapping it until the tank is level and the boot is unlevel.</p>	
<p>Water inside the tank is gray.</p>	<p>This is normal with all carbon filters and this will slowly fade away. The carbon inside the tank can still have air pockets inside that, when released, turn the water a little gray with carbon dust. The carbon dust is harmless.</p>
<p>Water pressure is slowing.</p>	<p>It is recommended that the sediment filter be replaced every 6-9 months depending on the amount of sediment present in the water supply. If the system has been working properly and the pressure is slowing, it may be time to change the sediment filter. Check the sediment filter and replace if necessary.</p>
<p>Water appears grey or cloudy.</p>	<p>Water may appear grey or cloudy for the first seven to ten days after installation due to extra carbon dust.</p>
<p>Water pressure is slowing immediately after installation.</p>	<p>High flow rates such as bathtubs, utility sinks, hose bibs, multi-headed showers, body sprayers, or anything that is considered high flow for the first 72 hours should be avoided. If you suspect a carbon blockage of the top basket due to a high-flow situation within the first 72 hours of installation, turn off any running water for at least 10 minutes. This will clear the blockage and you can resume using water at low or normal flow rates.</p>

Notice: If you have experienced a Boil Alert or require your system to be sanitized, please go to pentair.com/assets/pwsboilalert for product sanitization instructions.

PRODUCT WARRANTY AND REGISTRATION FORM

For details on your Pentair product warranty, please visit pentair.com/assets/residential-filtration-warranty.

Warranty Registration Form

Send in this Warranty Registration Form to validate your warranty or visit pentair.com/register-warranty to complete the warranty registration form online.

Date Item(s) were Received:	Order ID#:	Model:
_____	_____	_____
Dealer Purchased From:		

Model/Serial Number:		

Name:	_____	
Address:	_____	
City:	State:	Zip:
_____	_____	_____

Send to:

Pentair
2361 Mason Avenue, Suite 100
Daytona Beach, FL 32117

PRODUCT CERTIFICATIONS

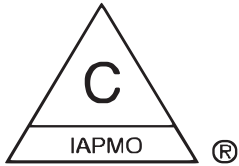

Pentair PC1665-P is certified By IAPMO R&T to NSF/ANSI 61 for material safety.

WARNING

Do not use where water is microbiologically unsafe or with water of unknown quality without proper disinfection before or after the filter/softener system.



2361 Mason Ave | Suite 100 | Daytona Beach, FL 32117 | United States
P: 877.842.1635 | Technical Services: 877.842.1635 | pentair.com/homewater

© 2021 Pentair. All indicated Pentair trademarks and logos are property of Pentair. Third party registered and unregistered trademarks and logos are the property of their respective owners.