

# MEDIUM PRESSURE POLY DIAPHRAGM PUMP

9915-DP503, 9915-DP503GRGI, 9915-DP503AP-A

## FEATURES

- Polypropylene over molded aluminum heads and manifolds.
- Three Duramax diaphragms, crown shaped pistons, and double piston rings.
- Valves: 316 stainless steel spherical profiled valve poppet.
- Inlet Port: 1-3/8"/40mm
- Outlet Port: 3/4" NPT
- Max Fluid Temp: 140°F/60°C
- Weight: 30.9 lbs/14 kg

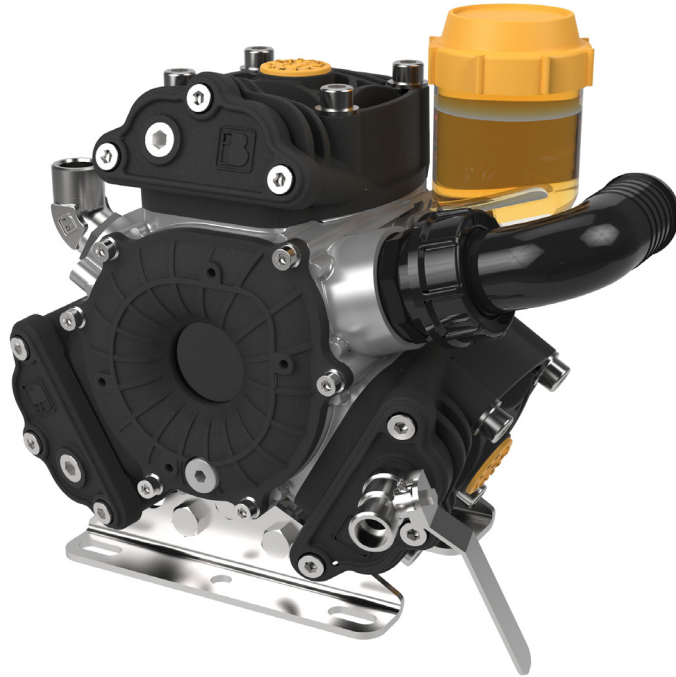

## PERFORMANCE INFORMATION

PRESSURE PSI	RPM							
	400		450		500		550	
	GPM	HP	GPM	HP	GPM	HP	GPM	HP
30	10.4	0.2	11.7	0.2	13.0	0.3	14.3	0.3
290	10.0	2.0	11.2	2.2	12.5	2.5	13.7	2.7
435	9.9	2.9	11.1	3.3	12.4	3.7	13.6	4.1
580	9.8	3.9	11.0	4.4	12.2	4.9	13.5	5.4

PRESSURE BAR	RPM							
	400		450		500		550	
	LPM	KW	LPM	KW	LPM	KW	LPM	KW
2	39.3	0.2	44.2	0.2	49.1	0.2	54.0	0.2
20	37.8	1.5	42.5	1.7	47.3	1.9	52.0	2.0
30	37.5	2.2	42.1	2.5	46.8	2.8	51.5	3.0
40	37.1	2.9	41.7	3.3	46.4	3.6	51.0	4.0

**DIMENSIONAL DATA**

9915-DP503GRGI

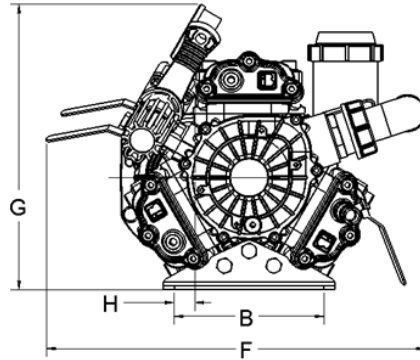
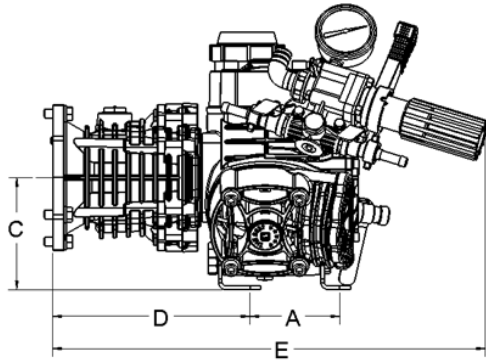

DIM	IN	MM
A	3.9	114
B	6.6	130
C	4.9	135
D	8.6	220
E	19.0	482
F	16.6	422
G	12.5	318
H	0.9	23

9915-DP503, 9915-DP503AP-A

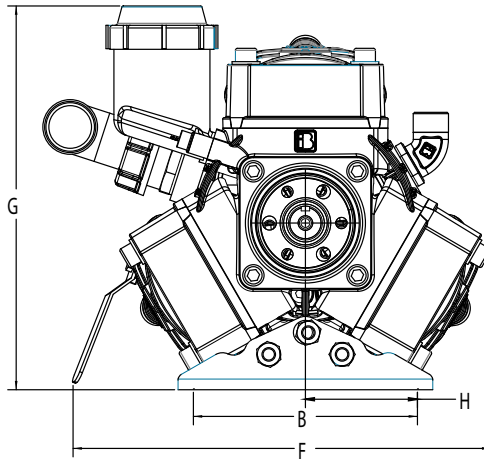
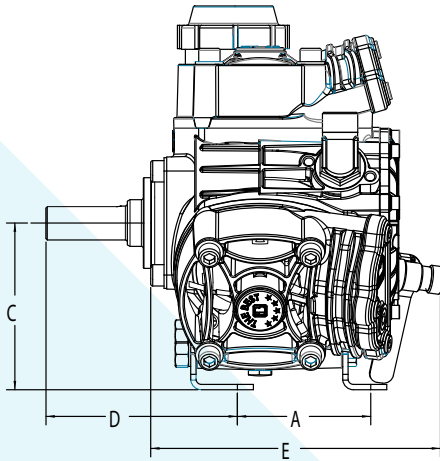

DIM	IN	MM
A	3.9	100
B	6.6	167
C	4.9	125
D	5.7	144
E	8.2	207
F	12.3	312
G	11.3	288
H	3.3	84

## ORDERING INFORMATION

MODEL NUMBER	DESCRIPTION	MAX FLOW GPM [LPM]	MAX PRESSURE PSI [BAR]	MAX SPEED RPM	POWER HP [KW]	NUMBER OF DIAPHRAGMS
9915-DP503	Pump Assembly	13.5 [51]	580 [40]	550	5.4 [4]	3
9915-DP503GRGI	Pump Gearbox Controller 1" Hollow Shaft			3450		
9915-DP503AP-A	Pump Assembly w/ 1" solid shaft			550		
9915-KIT1003	Control Unit					
9915-KIT1405	Control Unit Remote Mounting Kit					
9915-KIT2003	Diaphragm Kit					
9915-KIT2103	Valve Kit					
9915-KIT2203	Pump Kit					
9915-KIT1105	Gear Reduction Kit 1" Shaft					
9915-KIT1202	1" Shaft Kit					
9915-KIT1203	1-3/8" Male Splined Shaft Kit					



375 Fifth Ave NW,  
 New Brighton, MN 55112 U.S.  
 PHONE: 651-766-6300, 800-424-9776  
 FAX: 800-323-6496

[pentair.com](http://pentair.com)

All indicated Pentair trademarks and logos are property of Pentair. Third party registered and unregistered trademarks and logos are the property of their respective owners. Because we are continuously improving our products and services, Pentair reserves the right to change specifications without prior notice. Pentair is an equal opportunity employer.

HYP2110DS (04/15/2021) ©2021 Pentair. All Rights Reserved.