

EVERPURE ROM IV REVERSE OSMOSIS SYSTEM

Drinking water system: EV927077
Replacement Cartridge: EV927075



Third party certified



FEATURES • BENEFITS

- ◆ Quality water for your drinking and cooking needs
- ◆ Compact system fits under kitchen sink
- ◆ Sanitary cartridge replacement is simple, quick, and clean; internal filter parts are never exposed to handling or contamination
- ◆ Designed for chlorinated or non-chlorinated water supplies
- ◆ 14 gallon per day high recovery reverse osmosis membrane
- ◆ Most efficient RO technology available on the market today

SPECIFICATIONS

Feed Water Pressure
40-100 psi (2.7 - 6.9 bar)

Temperature Range
32-120°F (0-49°C)

Total Dissolved Solids
1000 ppm maximum

Maximum Hardness
143 ppm

Sulfide, Iron and Manganese:
Less than 0.1 ppm

Chlorine in Water Supply
Free chlorine - 0.1 ppm maximum

Water Supply pH Limits
4 to 11

Turbidity
1.0 NTU maximum

SUBSTANCE REDUCTION

Arsenic V

Barium

Cadmium

Chromium III

Chromium VI

Copper

Fluoride

Lead

Radium 226/228

Selenium

Total Dissolved Solids

Turbidity

Chlorine Taste & Odor

NSF/ANSI Standard 58 certified to reduce cysts such as *Cryptosporidium* and *Giardia* by mechanical means.

Dissolved Minerals & Salts

APPLICATIONS

Point-of-use drinking water
Undersink installations

SYSTEM INCLUDES

Membrane
Prefilter
Postfilter
Storage Tank
Faucet

EPA Est. No. 002623-IL-002

ORDERING INFORMATION

	MODEL	PART NO.	DESCRIPTION
	ROM IV	EV929650	RO System (w/faucet)
	ROM-G75	EV929775	RO Membrane
ROM-PFK	ROM-PRE	EV929670	Prefilter Cartridge**
	ROM-PST	EV929670	Postfilter Cartridge**

**Prefilter and Postfilter sold together as a twin pack (ROM-PFK)

INSTALLATION TIPS

Choose a mounting location suitable to support the full weight of the system when operating

The tank assembly may be placed above, below or alongside (preferred) of the assembly

Install vertically with cartridges hanging down

Allow 2-1/2" (6.35 cm) clearance below the cartridge for easy cartridge replacement

The water inlet must supply a minimum of 40-100 psi (2.7-6.9 bar), non-shock

OPERATION TIPS

Replace the Everpure prefilter and postfilter carbon cartridges every 12 months. Replace the Everpure ROM-G75 RO membrane cartridge every two (2) years, or as needed.

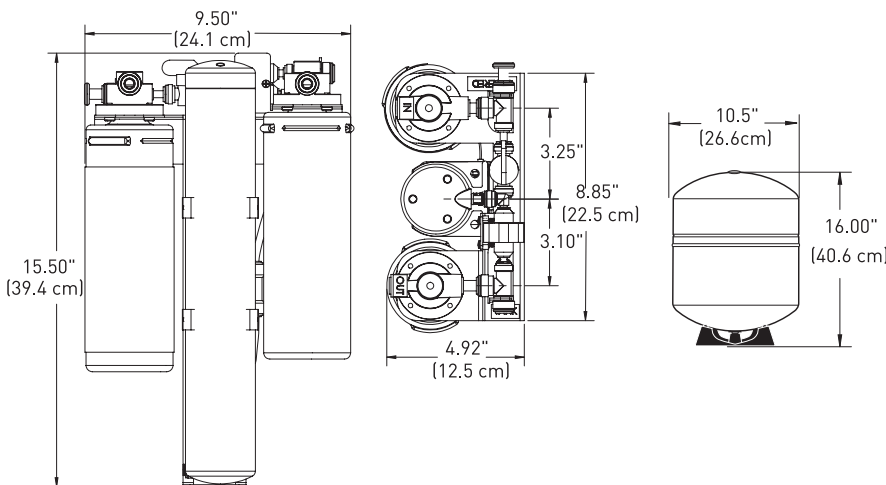

System Tested and Certified by NSF International against NSF/ANSI Standard 58 for the reduction of the claims specified on the performance data sheet or at www.NSF.org

The contaminants or other substances removed or reduced by this drinking water system are not necessarily in your water. Do not use with water that is microbiologically unsafe or of unknown quality without adequate disinfection before or after the system. Systems certified for cyst reduction may be used with disinfected water that may contain filterable cysts.

WARRANTY

Everpure ROM IV System by Pentair (excluding replaceable elements) is covered by a limited warranty against defects in material and workmanship for a period of one year after the date of purchase.

Everpure replaceable elements by Pentair (filter cartridges and water treatment cartridges) are covered by a limited warranty against defects in material and workmanship for a period of one year after date of purchase. See printed warranty for details. Pentair will provide a copy of the warranty upon request.



13845 Bishops Dr. | Suite 200 | Brookfield, WI 53005 | United States
P: 262.238.4400 | Customer Service: 800.279.9404 | tech-support@pentair.com | pentair.com

All indicated Pentair trademarks and logos are property of Pentair. Third party registered trademarks and logos are the property of their respective owners.

© 2021 Pentair. All rights reserved.

4005000 Rev F SE21