

AURORA[®]

Table of Contents	Page
PVM(X) 2 Series	2–8
PVM(X) 4 Series	9–15
PVM(X) 2 / PVM(X) 4 Construction Materials	16
PVM(X) 8 Series	17–23
PVM(X) 16 Series	24–28
PVM(X) 8 / PVM(X) 16 Construction Materials	29
PVM32 Series	30–33
PVM32 Construction Materials	34
Bypass Orifice Sizing and Vertical Multistage Performance	35

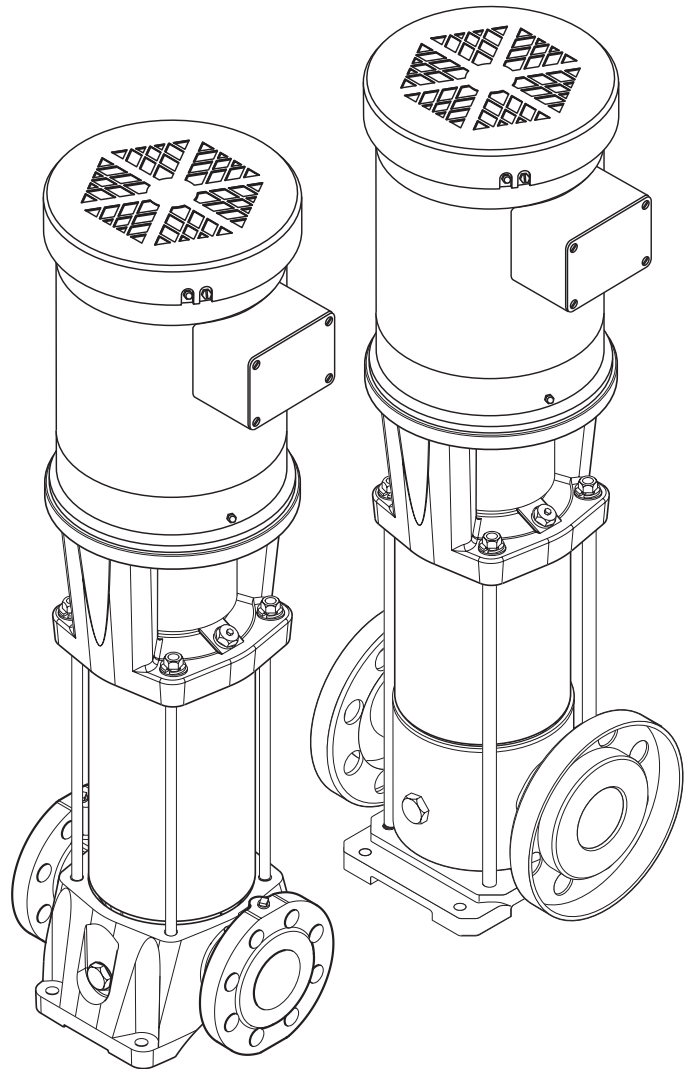

PVM – CAST IRON PVMX – 316 STAINLESS STEEL VERTICAL MULTISTAGE PUMPS 60 HERTZ

CATALOG

NOTE! To the installer: Please make sure you provide this manual to the owner of the equipment or to the responsible party who maintains the system.

AURORA® PVM(X)2 SERIES

PERFORMANCE CURVES

NOMINAL RPM: 3450 BASED ON FRESH WATER @ 68° F MAXIMUM WORKING PRESSURE: 360 PSI

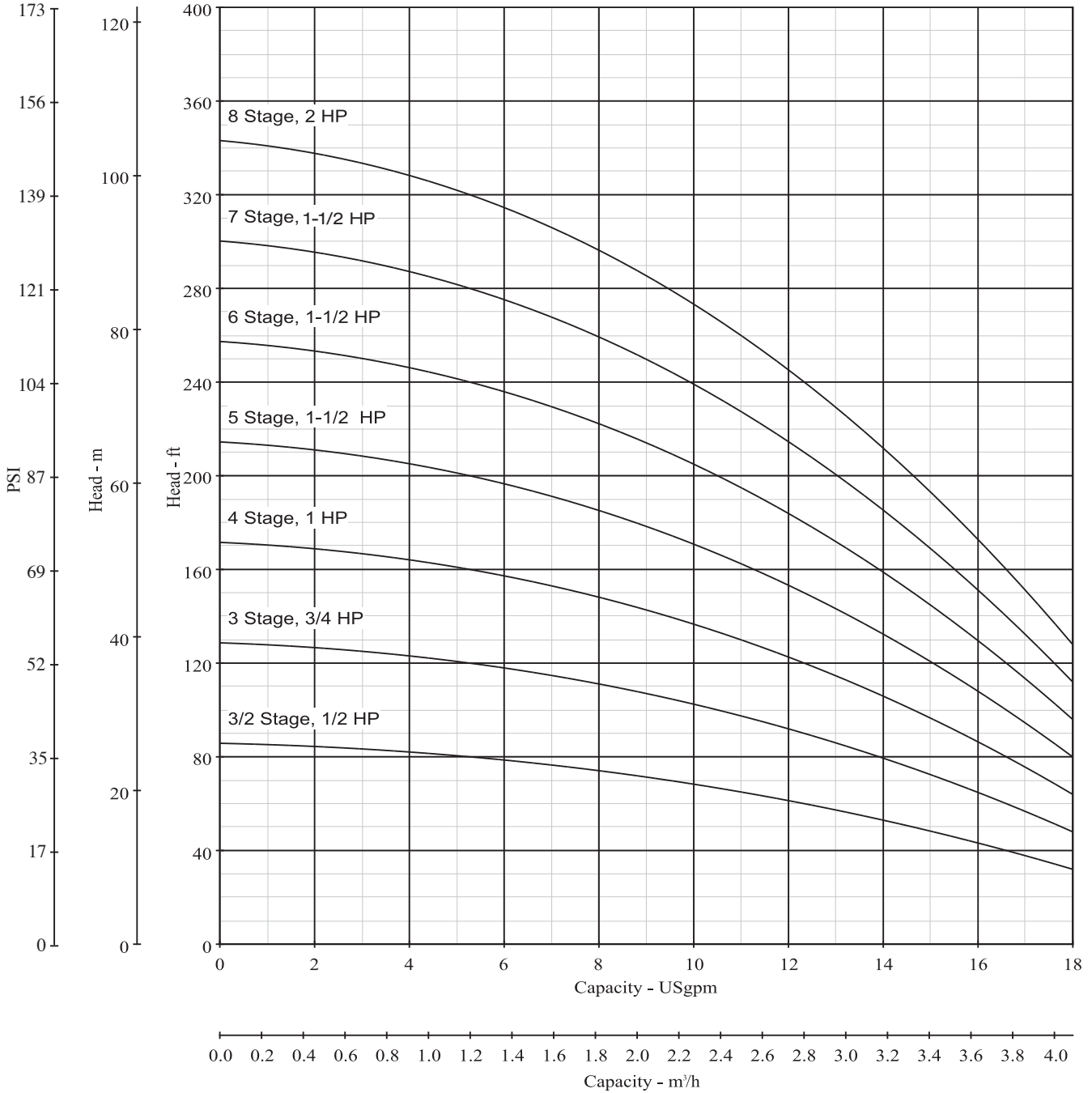

NOMINAL RPM: 3450 **BASED ON FRESH WATER @ 68° F** **MAXIMUM WORKING PRESSURE: 360 PSI**

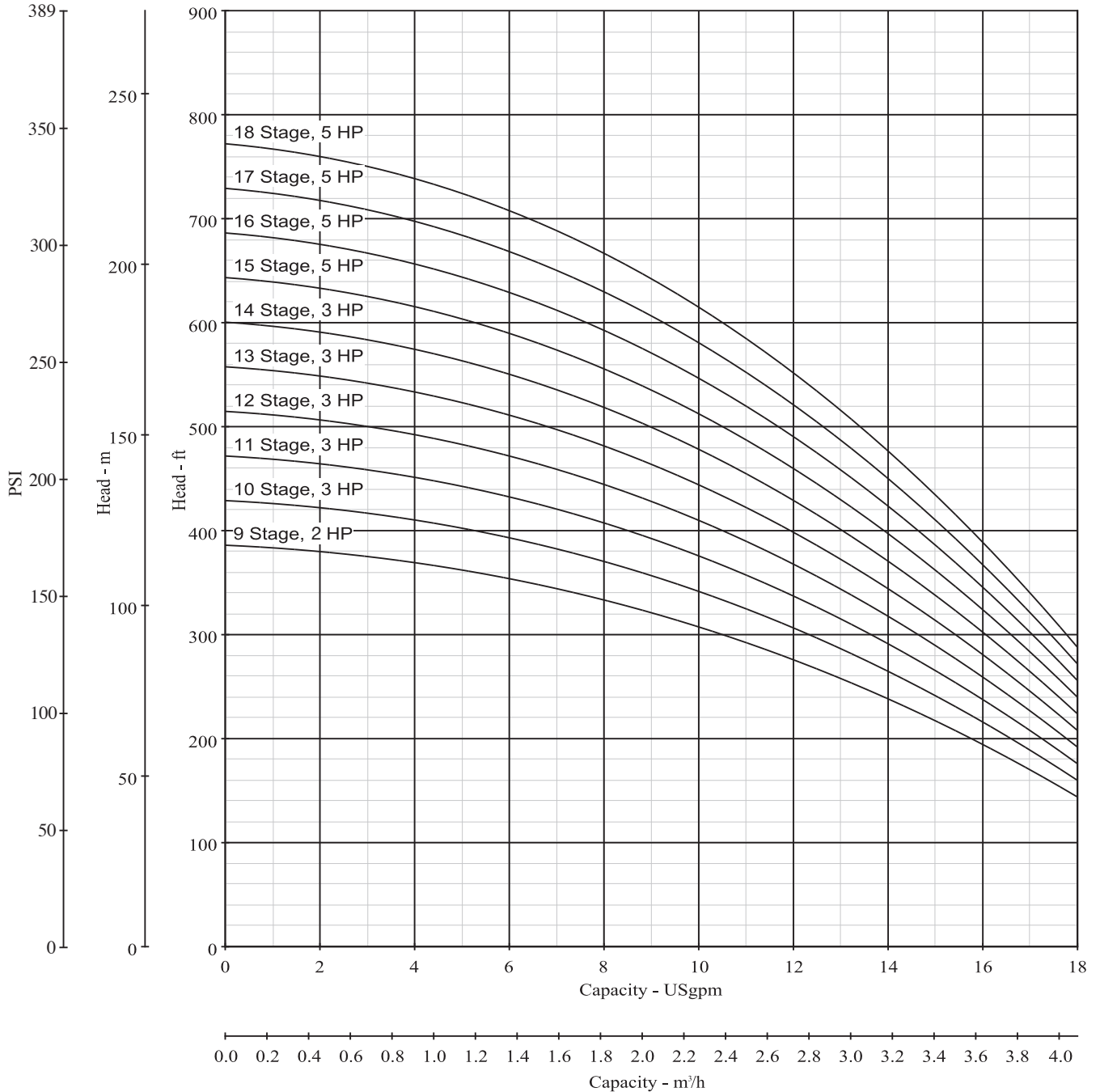

AURORA® PVM(X)2 SERIES

SINGLE STAGE PERFORMANCE DATA

NOMINAL RPM: 3450 **BASED ON FRESH WATER @ 68° F** **MAXIMUM WORKING PRESSURE: 360 PSI**

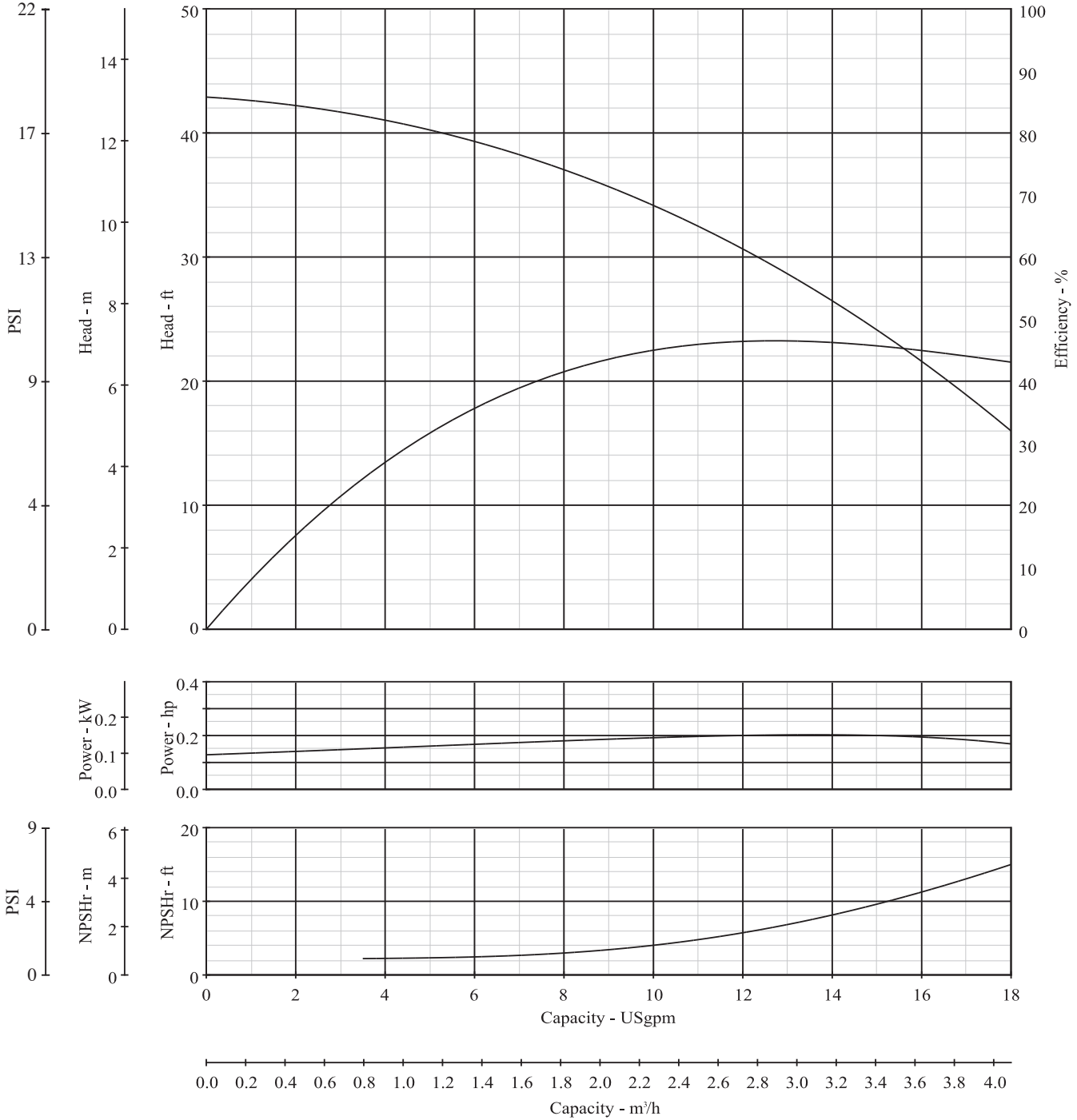

DIMENSIONS AND SPECIFICATIONS

Date May 2013

Supersedes November 2012

CAST IRON CONSTRUCTION

1/2 THROUGH 2 HP PUMPS

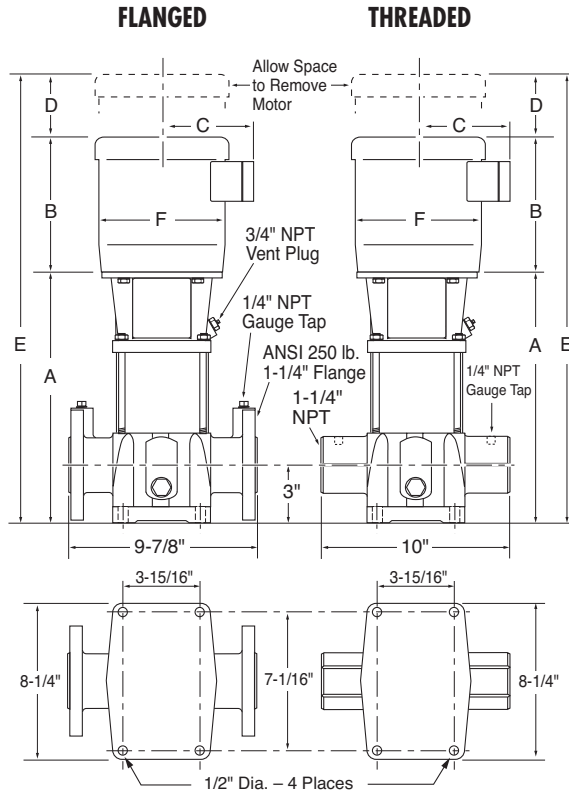
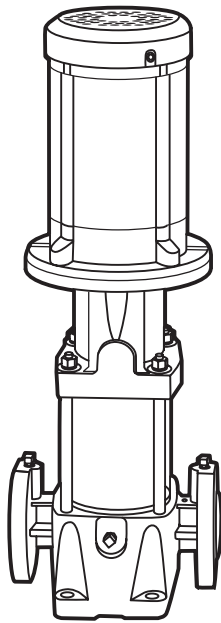

Technical Information	
MINIMUM PUMPING RATES	1.2 GPM
FLOW RANGE	1.2 – 20 GPM
MIN. SUCTION PIPE SIZES	1-1/4" Nominal Diameter, Schedule 40 Pipe
MAX. WORKING PRESSURE	360 PSI
MAX. AMBIENT TEMP.	104° F
LIQUID TEMP. RANGE	+5° F to +250° F
MOTOR OPTIONS	TEFC or ODP
CONSTRUCTION MATERIALS	See Page 16

1-1/4" ANSI. 250 lb. 4-Bolt Flange

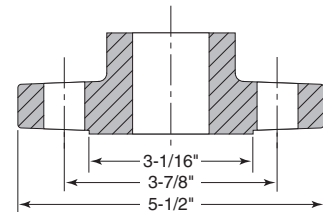

Model Number	HP	Motor S.F.	ph	Volts	Frame Size	Disc. Size	Suction Size	Dimensions in Inches*						TEFC Wt. (lbs.)	ODP Wt. (lbs.)
								A	B	C	D	E	F		
PVM2-30/2D	0.5	1.25	1	115/208-230	56CZ	1.25	1.25	11.3	9.3	4.5	2.0	22.6	6.0	65	69
PVM2-30/2D	0.5	1.25	3	208-230/460	56CZ	1.25	1.25	11.3	9.3	5.2	2.0	22.6	6.2	76	74
PVM2-30D	0.75	1.25	1	115/208-230	56CZ	1.25	1.25	11.3	9.3	4.5	2.0	22.6	6.0	74	75
PVM2-30D	0.75	1.25	3	208-230/460	56CZ	1.25	1.25	11.3	9.3	5.2	2.0	22.6	6.2	74	74
PVM2-40D	1	1.25	1	115/208-230	56CZ	1.25	1.25	12.1	10.1	5.3	2.0	24.2	7.2	81	80
PVM2-40D	1	1.25	3	208-230/460	56CZ	1.25	1.25	12.1	9.3	5.2	2.0	23.4	6.2	80	78
PVM2-50D	1.5	1.15	1	115/208-230	56CZ	1.25	1.25	12.8	10.1	5.7	2.0	24.9	7.2	92	84
PVM2-50D	1.5	1.15	3	208-230/460	56CZ	1.25	1.25	12.8	10.1	5.7	2.0	24.9	7.2	88	84
PVM2-60D	1.5	1.15	1	115/208-230	56CZ	1.25	1.25	13.5	10.1	5.7	2.0	25.6	7.2	94	86
PVM2-60D	1.5	1.15	3	208-230/460	56CZ	1.25	1.25	13.5	10.1	5.7	2.0	25.6	7.2	90	86
PVM2-70D	1.5	1.15	1	208-230	56CZ	1.25	1.25	14.2	10.1	5.7	2.0	26.3	7.2	102	96
PVM2-70D	1.5	1.15	3	208-230/460	56CZ	1.25	1.25	14.2	10.1	5.7	2.0	26.3	7.2	98	96
PVM2-80D	2	1.15	1	208-230	56CZ	1.25	1.25	14.9	10.1	5.7	2.0	27.0	7.2	103	97
PVM2-80D	2	1.15	3	208-230/460	56CZ	1.25	1.25	14.9	10.1	5.7	2.0	27.0	7.2	99	97

* Measurements represent the largest number possible for each model using standard efficiency motors. Weight may vary from published information.

AURORA® PVM2 SERIES

DIMENSIONS AND SPECIFICATIONS

CAST IRON CONSTRUCTION

3 THROUGH 5 HP PUMPS

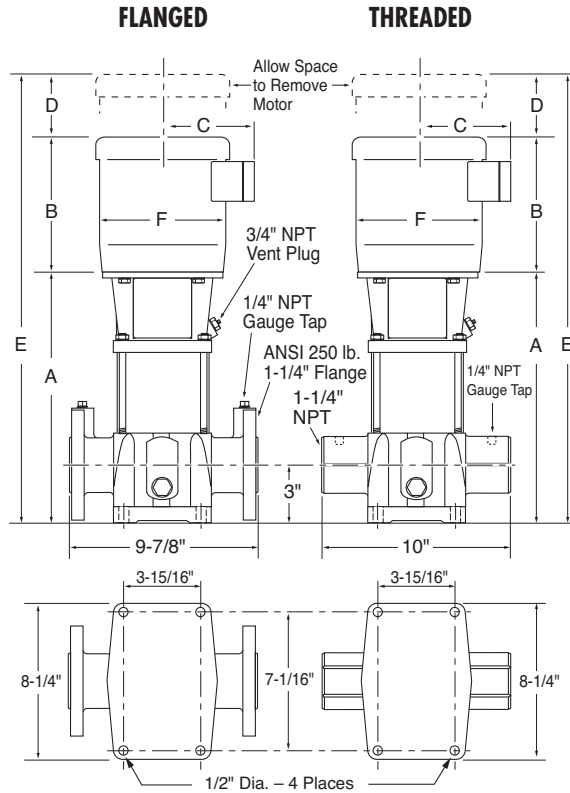
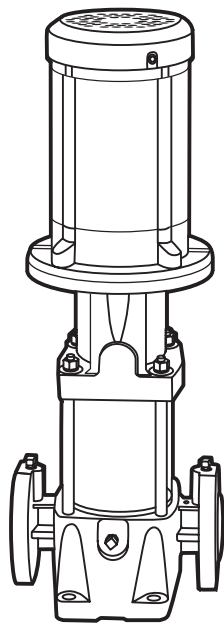

Technical Information	
MINIMUM PUMPING RATES	1.2 GPM
FLOW RANGE	1.2 – 20 GPM
MIN. SUCTION PIPE SIZES	1-1/4" Nominal Diameter, Schedule 40 Pipe
MAX. WORKING PRESSURE	360 PSI
MAX. AMBIENT TEMP.	104° F
LIQUID TEMP. RANGE	+5° F to +250° F
MOTOR OPTIONS	TEFC or ODP
CONSTRUCTION MATERIALS	See Page 16

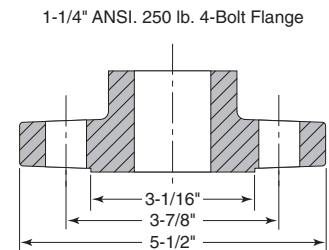

Model Number	HP	Motor S.F.	ph	Volts	Frame Size	Disc. Size	Suction Size	Dimensions in Inches*						TEFC Wt. (lbs.)	ODP Wt. (lbs.)
								A	B	C	D	E	F		
PVM2-90D	2	1.15	1	115/208-230	56CZ	1.25	1.25	15.8	12.6	6.8	2.6	31.0	8.9	143	125
PVM2-90D	2	1.15	3	208-230/460	56CZ	1.25	1.25	15.8	12.6	6.9	2.6	31.0	8.6	123	120
PVM2-100D	3	1.15	1	208-230	182TCZ	1.25	1.25	16.5	12.6	6.8	2.6	31.7	8.9	144	126
PVM2-100D	3	1.15	3	208-230/460	182TCZ	1.25	1.25	16.5	12.6	6.9	2.6	31.7	8.6	124	121
PVM2-110D	3	1.15	1	115/208-230	182TCZ	1.25	1.25	17.2	12.6	6.8	2.6	32.4	8.9	145	127
PVM2-110D	3	1.15	3	208-230/460	182TCZ	1.25	1.25	17.2	12.6	6.9	2.6	32.4	8.6	125	122
PVM2-120D	3	1.15	1	208-230	182TCZ	1.25	1.25	17.9	12.6	6.8	2.6	33.1	8.9	147	129
PVM2-120D	3	1.15	3	208-230/460	182TCZ	1.25	1.25	17.9	12.6	6.9	2.6	33.1	8.6	127	124
PVM2-130D	3	1.15	1	115/208-230	182TCZ	1.25	1.25	18.6	13.9	7.9	2.6	35.1	10.0	148	130
PVM2-130D	3	1.15	3	208-230/460	182TCZ	1.25	1.25	18.6	12.6	6.9	2.6	33.8	8.6	128	125
PVM2-140D	3	1.15	1	208-230	182TCZ	1.25	1.25	19.3	13.9	7.9	2.6	35.8	10.0	149	131
PVM2-140D	3	1.15	3	208-230/460	182TCZ	1.25	1.25	19.3	12.6	6.9	2.6	34.5	8.6	129	126
PVM2-150D	5	1.15	1	208-230	213TCZ	1.25	1.25	20.0	13.9	7.9	2.6	36.5	10.0	171	179
PVM2-150D	5	1.15	3	208-230/460	184TCZ	1.25	1.25	20.0	12.6	6.9	2.6	35.2	8.6	145	138
PVM2-160D	5	1.15	1	208-230	213TCZ	1.25	1.25	20.8	13.9	7.9	2.6	37.3	10.0	172	180
PVM2-160D	5	1.15	3	208-230/460	184TCZ	1.25	1.25	20.8	12.6	6.9	2.6	36.0	8.6	146	139
PVM2-170D	5	1.15	1	208-230	213TCZ	1.25	1.25	21.5	13.9	7.9	2.6	38.0	10.0	174	182
PVM2-170D	5	1.15	3	208-230/460	184TCZ	1.25	1.25	21.5	12.6	6.9	2.6	36.7	8.6	148	141
PVM2-180D	5	1.15	1	208-230	213TCZ	1.25	1.25	22.2	13.9	7.9	2.6	38.7	10.0	175	183
PVM2-180D	5	1.15	3	208-230/460	184TCZ	1.25	1.25	22.2	12.6	6.9	2.6	37.4	8.6	149	142

* Measurements represent the largest number possible for each model using standard efficiency motors. Weight may vary from published information.

DIMENSIONS AND SPECIFICATIONS

Date May 2013
Supersedes November 2012

316 SS CONSTRUCTION
1/2 THROUGH 2 HP PUMPS

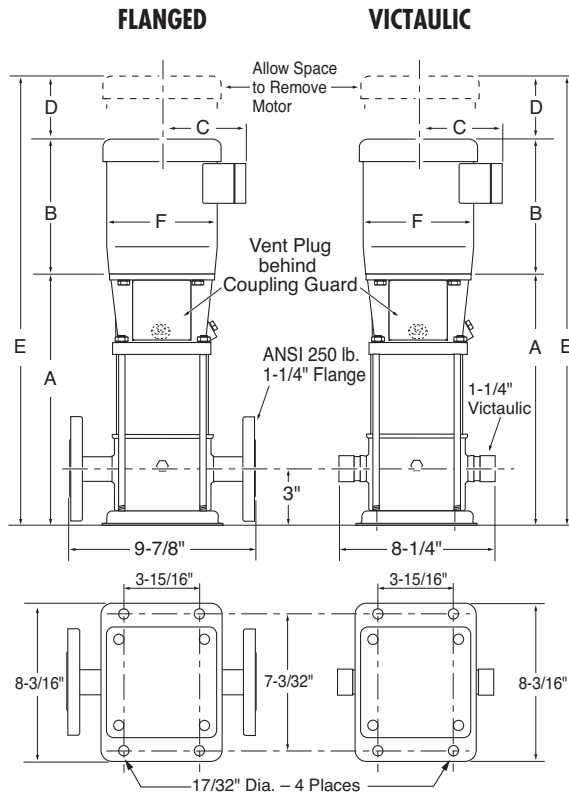
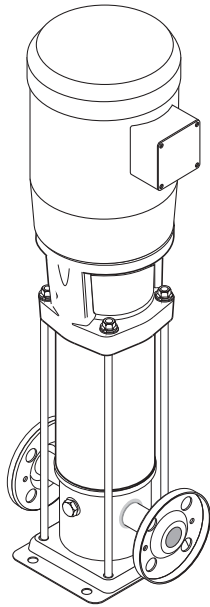

Technical Information	
MINIMUM PUMPING RATES	1.2 GPM
FLOW RANGE	1.2 – 20 GPM
MIN. SUCTION PIPE SIZES	1-1/4" Nominal Diameter, Schedule 40 Pipe
MAX. WORKING PRESSURE	360 PSI
MAX. AMBIENT TEMP.	104° F
LIQUID TEMP. RANGE	+5° F to +250° F
MOTOR OPTIONS	TEFC or ODP
CONSTRUCTION MATERIALS	See Page 16

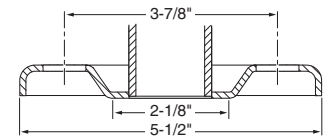

Model Number	HP	Motor S.F.	ph	Volts	Frame Size	Disc. Size	Suction Size	Dimensions in Inches*						TEFC Wt. (lbs.)	ODP Wt. (lbs.)
								A	B	C	D	E	F		
PVM(I/X)2-30/2D	0.5	1.25	1	115/208-230	56CZ	1.25	1.25	11.9	9.3	4.5	2.0	23.2	6.0	51	55
PVM(I/X)2-30/2D	0.5	1.25	3	208-230/460	56CZ	1.25	1.25	11.9	9.3	5.2	2.0	23.2	6.2	62	60
PVM(I/X)2-30D	0.75	1.25	1	115/208-230	56CZ	1.25	1.25	11.9	9.3	4.5	2.0	23.2	6.0	61	62
PVM(I/X)2-30D	0.75	1.25	3	208-230/460	56CZ	1.25	1.25	11.9	9.3	5.2	2.0	23.2	6.2	61	61
PVM(I/X)2-40D	1	1.25	1	115/208-230	56CZ	1.25	1.25	12.6	10.1	5.3	2.0	24.7	7.2	68	67
PVM(I/X)2-40D	1	1.25	3	208-230/460	56CZ	1.25	1.25	12.6	9.3	5.2	2.0	23.9	6.2	67	65
PVM(I/X)2-50D	1.5	1.15	1	115/208-230	56CZ	1.25	1.25	13.3	10.1	5.7	2.0	25.4	7.2	79	71
PVM(I/X)2-50D	1.5	1.15	3	208-230/460	56CZ	1.25	1.25	13.3	10.1	5.7	2.0	25.4	7.2	75	71
PVM(I/X)2-60D	1.5	1.15	1	115/208-230	56CZ	1.25	1.25	14.1	10.1	5.7	2.0	26.2	7.2	80	72
PVM(I/X)2-60D	1.5	1.15	3	208-230/460	56CZ	1.25	1.25	14.1	10.1	5.7	2.0	26.2	7.2	76	72
PVM(I/X)2-70D	1.5	1.15	1	208-230	56CZ	1.25	1.25	14.8	10.1	5.7	2.0	26.9	7.2	88	82
PVM(I/X)2-70D	1.5	1.15	3	208-230/460	56CZ	1.25	1.25	14.8	10.1	5.7	2.0	26.9	7.2	84	82
PVM(I/X)2-80D	2	1.15	1	208-230	56CZ	1.25	1.25	15.5	10.1	5.7	2.0	27.6	7.2	89	83
PVM(I/X)2-80D	2	1.15	3	208-230/460	56CZ	1.25	1.25	15.5	10.1	5.7	2.0	27.6	7.2	85	83

*Measurements represent the largest number possible for each model using standard efficiency motors.

AURORA® PVM(I/X)2 SERIES

DIMENSIONS AND SPECIFICATIONS

316 SS CONSTRUCTION

3 THROUGH 5 HP PUMPS

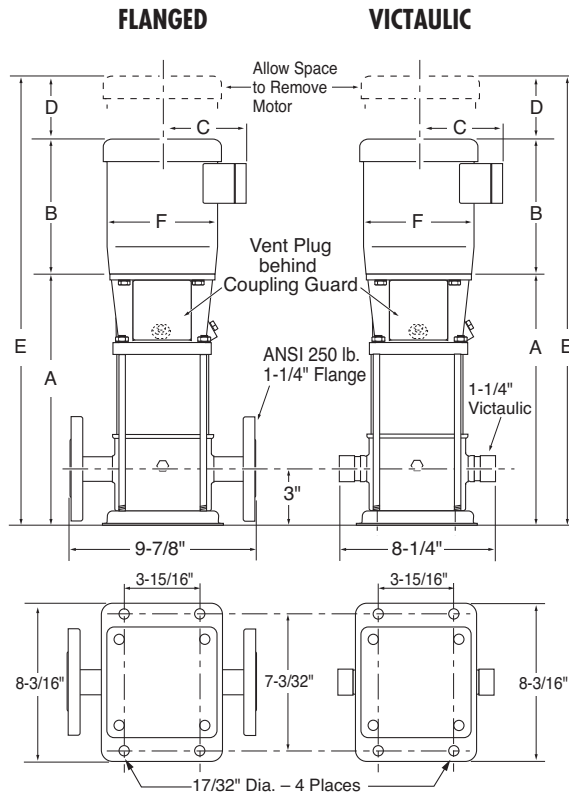
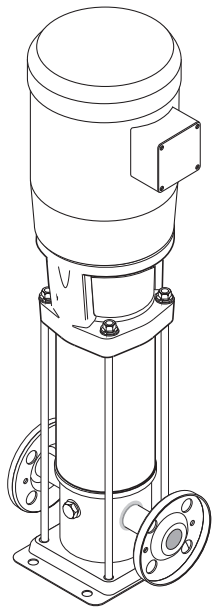

Technical Information	
MINIMUM PUMPING RATES	1.2 GPM
FLOW RANGE	1.2 – 20 GPM
MIN. SUCTION PIPE SIZES	1-1/4" Nominal Diameter, Schedule 40 Pipe
MAX. WORKING PRESSURE	360 PSI
MAX. AMBIENT TEMP.	104° F
LIQUID TEMP. RANGE	+5° F to +250° F
MOTOR OPTIONS	TEFC or ODP
CONSTRUCTION MATERIALS	See Page 16

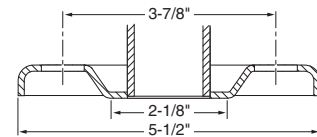

Model Number	HP	Motor S.F.	ph	Volts	Frame Size	Disc. Size	Suction Size	Dimensions in Inches*						TEFC Wt. (lbs.)	ODP Wt. (lbs.)
								A	B	C	D	E	F		
PVM(I/X)2-90D	2	1.15	1	115/208-230	56CZ	1.25	1.25	16.2	12.6	6.8	2.6	31.4	8.9	130	112
PVM(I/X)2-90D	2	1.15	3	230/460	56CZ	1.25	1.25	16.2	12.6	6.9	2.6	31.4	8.6	110	107
PVM(I/X)2-100D	3	1.15	1	208-230	182TCZ	1.25	1.25	16.9	12.6	6.8	2.6	32.1	8.9	131	113
PVM(I/X)2-100D	3	1.15	3	208-230/460	182TCZ	1.25	1.25	16.9	12.6	6.9	2.6	32.1	8.6	111	108
PVM(I/X)2-110D	3	1.15	1	115/208-230	182TCZ	1.25	1.25	17.6	12.6	6.8	2.6	32.8	8.9	132	114
PVM(I/X)2-110D	3	1.15	3	230/460	182TCZ	1.25	1.25	17.6	12.6	6.9	2.6	32.8	8.6	112	109
PVM(I/X)2-120D	3	1.15	1	208-230	182TCZ	1.25	1.25	18.3	12.6	6.8	2.6	33.5	8.9	133	115
PVM(I/X)2-120D	3	1.15	3	208-230/460	182TCZ	1.25	1.25	18.3	12.6	6.9	2.6	33.5	8.6	113	110
PVM(I/X)2-130D	3	1.15	1	115/208-230	182TCZ	1.25	1.25	19.0	13.9	7.9	2.6	35.5	10.0	134	116
PVM(I/X)2-130D	3	1.15	3	208-230/460	182TCZ	1.25	1.25	19.0	12.6	6.9	2.6	34.2	8.6	114	111
PVM(I/X)2-140D	3	1.15	1	208-230	182TCZ	1.25	1.25	19.7	13.9	7.9	2.6	36.2	10.0	135	117
PVM(I/X)2-140D	3	1.15	3	208-230/460	182TCZ	1.25	1.25	19.7	12.6	6.9	2.6	34.9	8.6	115	112
PVM(I/X)2-150D	5	1.15	1	208-230	213TCZ	1.25	1.25	20.4	13.9	7.9	2.6	36.9	10.0	158	166
PVM(I/X)2-150D	5	1.15	3	208-230/460	184TCZ	1.25	1.25	20.4	12.6	6.9	2.6	35.6	8.6	132	125
PVM(I/X)2-160D	5	1.15	1	208-230	213TCZ	1.25	1.25	21.1	13.9	7.9	2.6	37.6	10.0	159	167
PVM(I/X)2-160D	5	1.15	3	208-230/460	184TCZ	1.25	1.25	21.1	12.6	6.9	2.6	36.3	8.6	133	126
PVM(I/X)2-170D	5	1.15	1	208-230	213TCZ	1.25	1.25	21.8	13.9	7.9	2.6	38.3	10.0	160	168
PVM(I/X)2-170D	5	1.15	3	208-230/460	184TCZ	1.25	1.25	21.8	12.6	6.9	2.6	37.0	8.6	134	127
PVM(I/X)2-180D	5	1.15	1	208-230	213TCZ	1.25	1.25	22.6	13.9	7.9	2.6	39.1	10.0	161	169
PVM(I/X)2-180D	5	1.15	3	208-230/460	184TCZ	1.25	1.25	22.6	12.6	6.9	2.6	37.8	8.6	135	128

*Measurements represent the largest number possible for each model using standard efficiency motors.

NOMINAL RPM: 3450

BASED ON FRESH WATER @ 68° F

MAXIMUM WORKING PRESSURE: 360 PSI

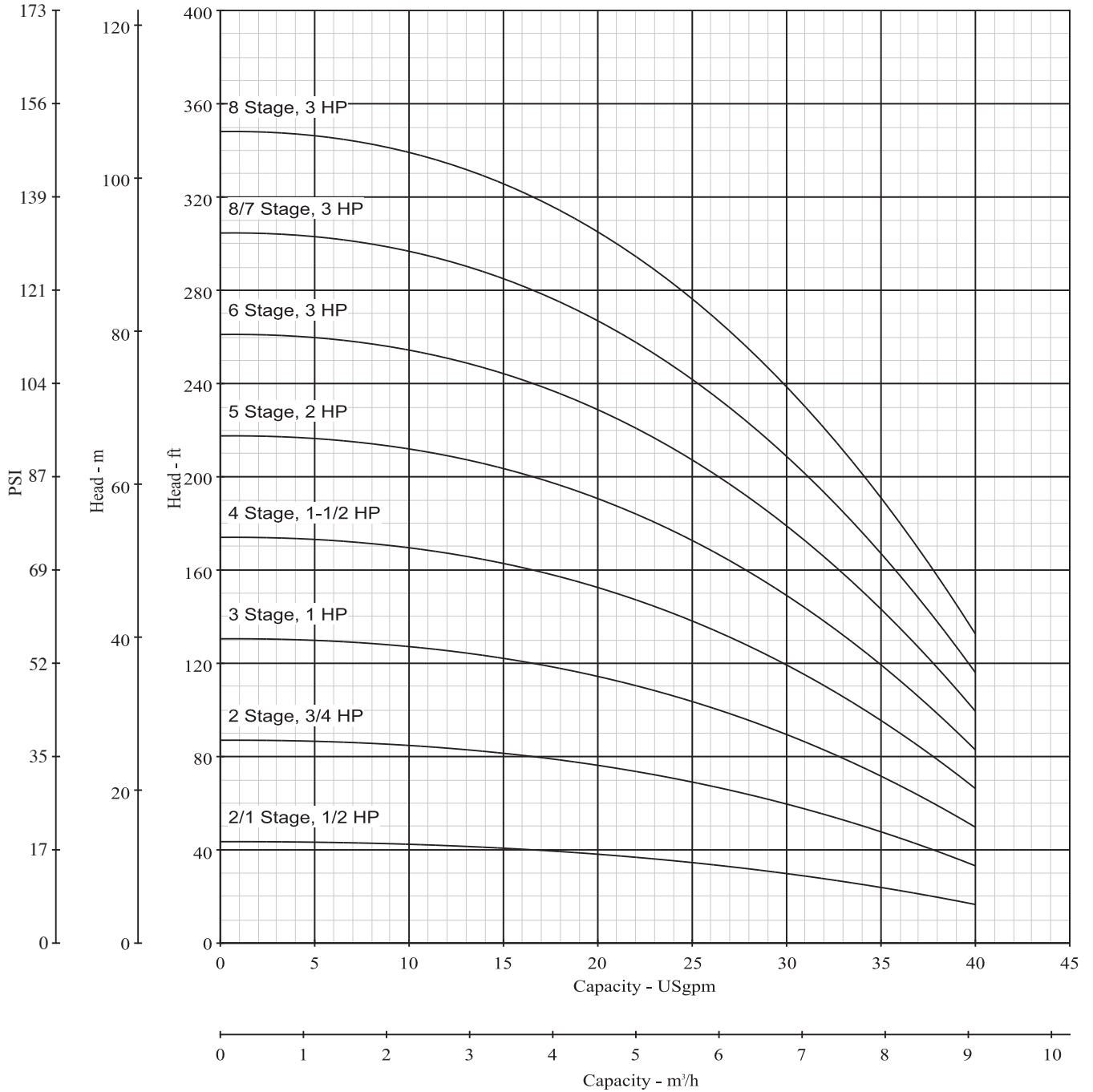

AURORA® PVM(X)4 SERIES

PERFORMANCE CURVES

NOMINAL RPM: 3450 **BASED ON FRESH WATER @ 68° F** **MAXIMUM WORKING PRESSURE: 360 PSI**

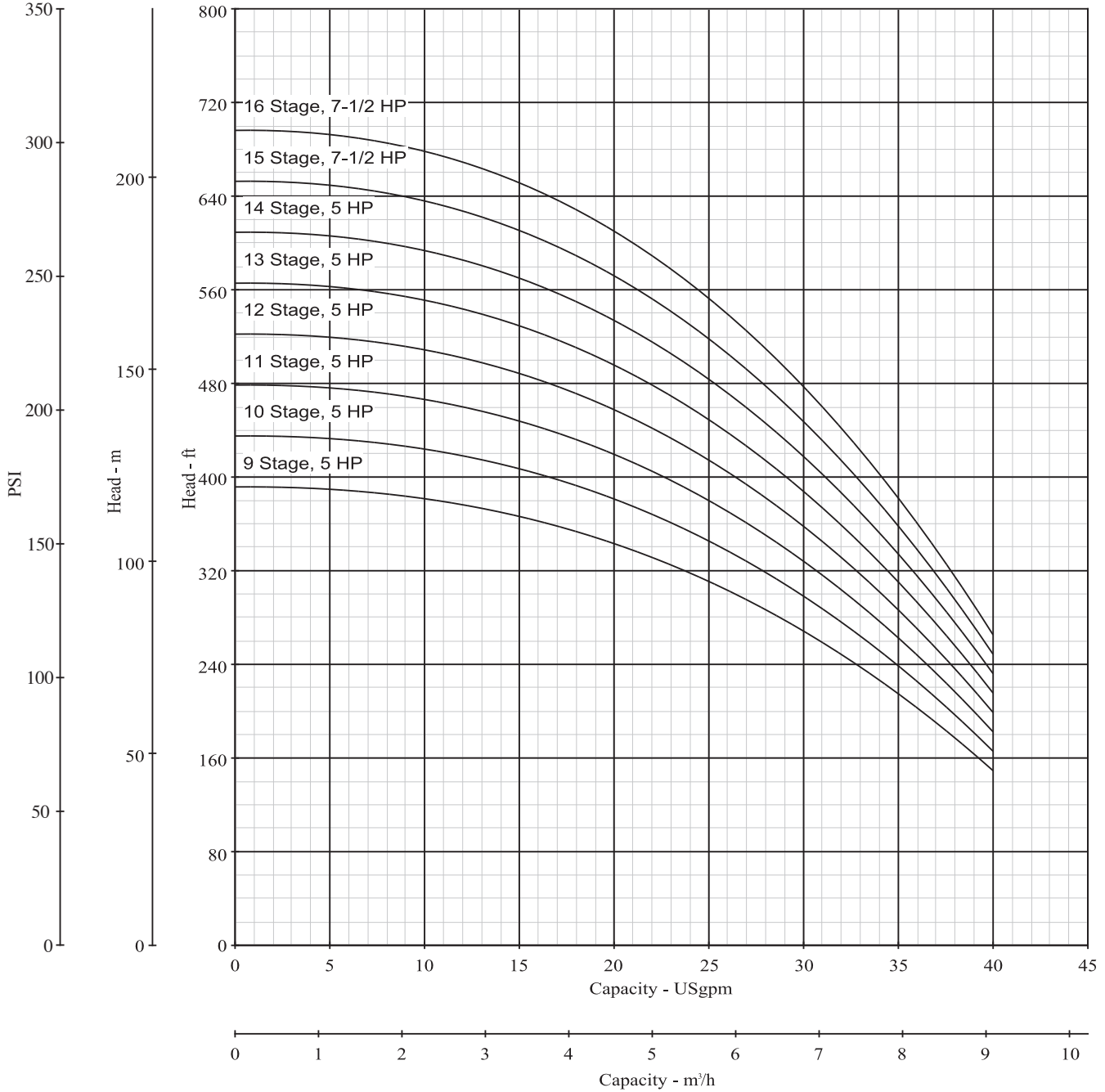

AURORA® PVM(X)4 SERIES

SINGLE STAGE PERFORMANCE DATA

NOMINAL RPM: 3450 **BASED ON FRESH WATER @ 68° F** **MAXIMUM WORKING PRESSURE: 360 PSI**

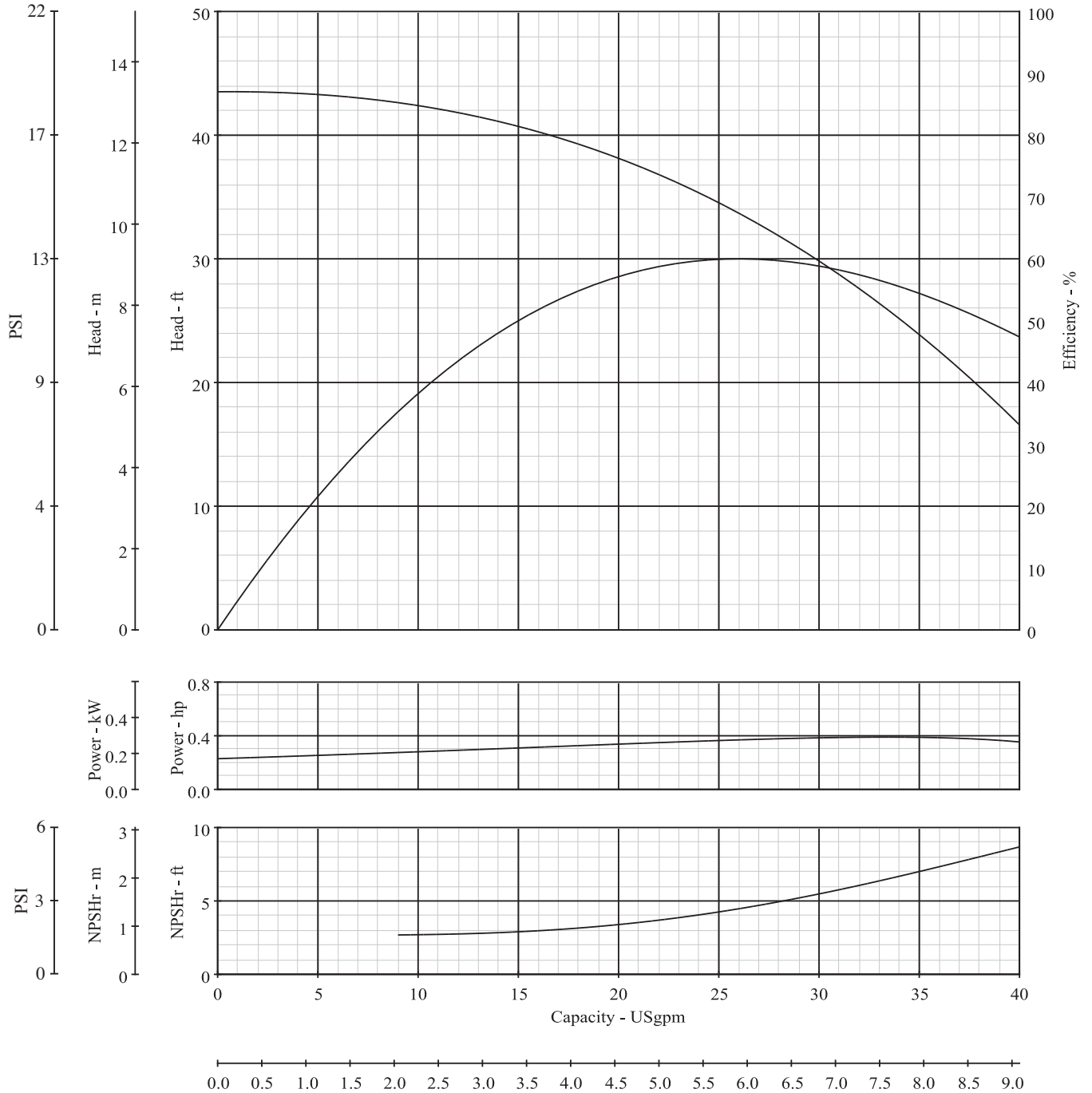

AURORA® PVM4 SERIES

DIMENSIONS AND SPECIFICATIONS

CAST IRON CONSTRUCTION

1/2 THROUGH 2 HP PUMPS

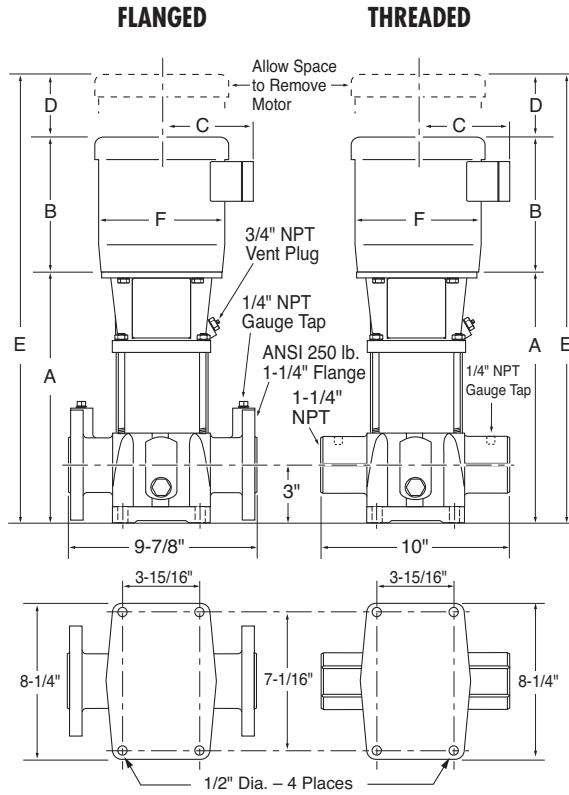
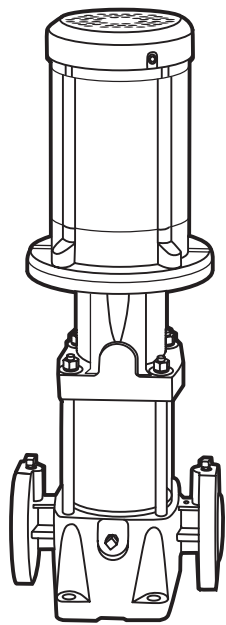

TECHNICAL INFORMATION	
MINIMUM PUMPING RATES	3 GPM
FLOW RANGE	3 – 40 GPM
MIN. SUCTION PIPE SIZES	1-1/4" Nominal Diameter, Schedule 40 Pipe
MAX. WORKING PRESSURE	360 PSI
MAX. AMBIENT TEMP.	104° F
LIQUID TEMP. RANGE	+5° F to +250° F
MOTOR OPTIONS	TEFC or ODP
CONSTRUCTION MATERIALS	See Page 16

1-1/4" ANSI. 250 lb. 4-Bolt Flange

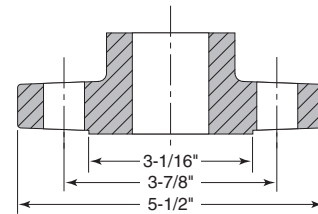

Model Number	HP	Motor S.F.	ph	Volts	Frame Size	Disc. Size	Suction Size	Dimensions in Inches*						TEFC Wt. (lbs.)	ODP Wt. (lbs.)
								A	B	C	D	E	F		
PVM4-20/1D	0.5	1.25	1	115/208-230	56CZ	1.25	1.25	11.3	9.3	4.5	2.0	22.6	6.0	64	68
PVM4-20/1D	0.5	1.25	3	208-230/460	56CZ	1.25	1.25	11.3	9.3	5.2	2.0	22.6	6.2	75	73
PVM4-20D	0.75	1.25	1	115/208-230	56CZ	1.25	1.25	11.3	9.3	4.5	2.0	22.6	6.0	73	74
PVM4-20D	0.75	1.25	3	208-230/460	56CZ	1.25	1.25	11.3	9.3	5.2	2.0	22.6	6.2	73	73
PVM4-30D	1	1.25	1	115/208-230	56CZ	1.25	1.25	12.4	10.1	5.3	2.0	24.5	7.2	80	79
PVM4-30D	1	1.15	3	208-230/460	56CZ	1.25	1.25	12.4	9.3	5.2	2.0	23.7	6.2	79	77
PVM4-40D	1.5	1.25	1	115/208-230	56CZ	1.25	1.25	13.5	10.1	5.7	2.0	25.6	7.2	92	84
PVM4-40D	1.5	1.15	3	208-230/460	56CZ	1.25	1.25	13.5	10.1	5.7	2.0	25.6	7.2	88	84
PVM4-50D	2	1.15	1	208-230	56CZ	1.25	1.25	14.5	10.1	5.7	2.0	26.6	7.2	100	94
PVM4-50D	2	1.15	3	208-230/460	56CZ	1.25	1.25	14.5	10.1	5.7	2.0	26.6	7.2	96	94

*Measurements represent the largest number possible for each model using standard efficiency motors.

DIMENSIONS AND SPECIFICATIONS

Date May 2013

Supersedes November 2012

CAST IRON CONSTRUCTION

3 THROUGH 7-1/2 HP PUMPS

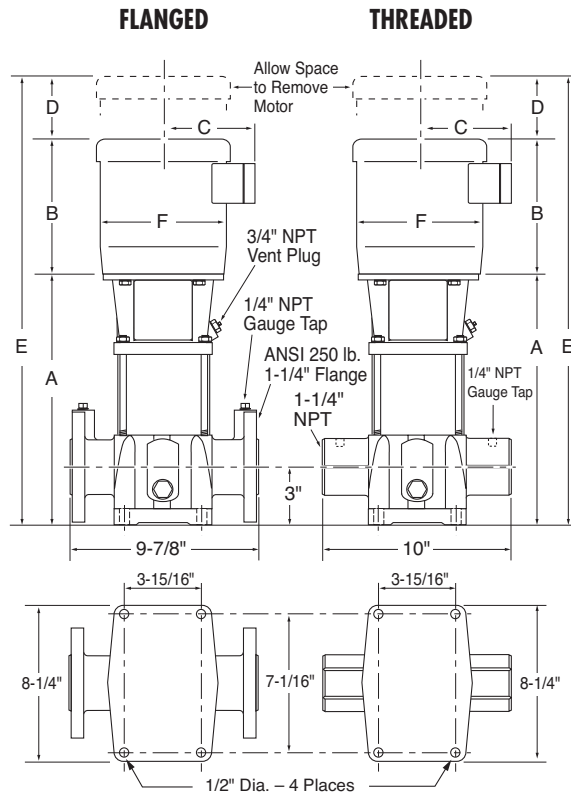
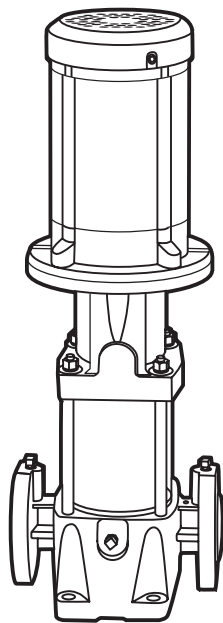

TECHNICAL INFORMATION	
MINIMUM PUMPING RATES	3 GPM
FLOW RANGE	3 – 40 GPM
MIN. SUCTION PIPE SIZES	1-1/4" Nominal Diameter, Schedule 40 Pipe
MAX. WORKING PRESSURE	360 PSI
MAX. AMBIENT TEMP.	104° F
LIQUID TEMP. RANGE	+5° F to +250° F
MOTOR OPTIONS	TEFC or ODP
CONSTRUCTION MATERIALS	See Page 16

1-1/4" ANSI. 250 lb. 4-Bolt Flange

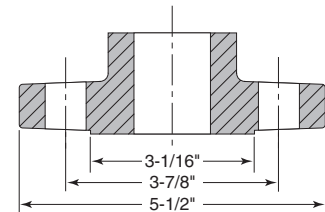

Model Number	HP	Motor S.F.	ph	Volts	Frame Size	Disc. Size	Suction Size	Dimensions in Inches*						TEFC Wt. (lbs.)	ODP Wt. (lbs.)
								A	B	C	D	E	F		
PVM4-60D	3	1.15	1	208-230	182TCZ	1.25	1.25	15.8	13.9	7.9	2.6	32.3	10.0	140	122
PVM4-60D	3	1.15	3	208-230/460	182TCZ	1.25	1.25	15.8	12.6	6.9	2.6	31.0	8.6	120	117
PVM4-80/7D	3	1.15	1	208-230	182TCZ	1.25	1.25	17.9	13.9	7.9	2.6	34.4	10.0	143	125
PVM4-80/7D	3	1.15	3	208-230/460	182TCZ	1.25	1.25	17.9	12.6	6.9	2.6	33.1	8.6	123	120
PVM4-80D	3	1.15	1	208-230	182TCZ	1.25	1.25	17.9	13.9	7.9	2.6	34.4	10.0	143	125
PVM4-80D	3	1.15	3	208-230/460	182TCZ	1.25	1.25	17.9	12.6	6.9	2.6	33.1	8.6	123	120
PVM4-90D	5	1.15	1	208-230	213TCZ	1.25	1.25	19.0	13.9	7.9	2.6	35.5	10.0	165	173
PVM4-90D	5	1.15	3	208-230/460	184TCZ	1.25	1.25	19.0	12.6	6.9	2.6	34.2	8.6	139	132
PVM4-100D	5	1.15	1	208-230	213TCZ	1.25	1.25	20.0	13.9	7.9	2.6	36.5	10.0	166	174
PVM4-100D	5	1.15	3	208-230/460	184TCZ	1.25	1.25	20.0	12.6	6.9	2.6	35.2	8.6	140	133
PVM4-110D	5	1.15	1	208-230	213TCZ	1.25	1.25	21.1	13.9	7.9	2.6	37.6	10.0	167	175
PVM4-110D	5	1.15	3	208-230/460	184TCZ	1.25	1.25	21.1	12.6	6.9	2.6	36.3	8.6	141	134
PVM4-120D	5	1.15	1	208-230	213TCZ	1.25	1.25	22.2	13.9	7.9	2.6	38.7	10.0	169	177
PVM4-120D	5	1.15	3	208-230/460	184TCZ	1.25	1.25	22.2	12.6	6.9	2.6	37.4	8.6	143	136
PVM4-130D	5	1.15	1	208-230	213TCZ	1.25	1.25	23.2	13.9	7.9	2.6	39.7	10.0	170	178
PVM4-130D	5	1.15	3	208-230/460	184TCZ	1.25	1.25	23.2	12.6	6.9	2.6	38.4	8.6	144	137
PVM4-140D	5	1.15	1	208-230	213TCZ	1.25	1.25	24.3	13.9	7.9	2.6	40.8	10.0	171	179
PVM4-140D	5	1.15	3	208-230/460	184TCZ	1.25	1.25	24.3	12.6	6.9	2.6	39.5	8.6	145	138
PVM4-150D	7.5	1.15	1	208-230	213TCZ	1.25	1.25	25.4	13.9	7.9	2.6	41.9	10.0	187	181
PVM4-150D	7.5	1.15	3	208-230/460	213TCZ	1.25	1.25	25.4	13.9	8.1	2.6	41.9	10.3	191	191
PVM4-160D	7.5	1.15	1	208-230	213TCZ	1.25	1.25	26.4	13.9	7.9	2.6	42.9	10.0	188	182
PVM4-160D	7.5	1.15	3	208-230/460	213TCZ	1.25	1.25	26.4	13.9	8.1	2.6	42.9	10.3	192	192

*Measurements represent the largest number possible for each model using standard efficiency motors.

AURORA® PVM(I/X)4 SERIES

DIMENSIONS AND SPECIFICATIONS

316 SS CONSTRUCTION

1/2 THROUGH 2 HP PUMPS

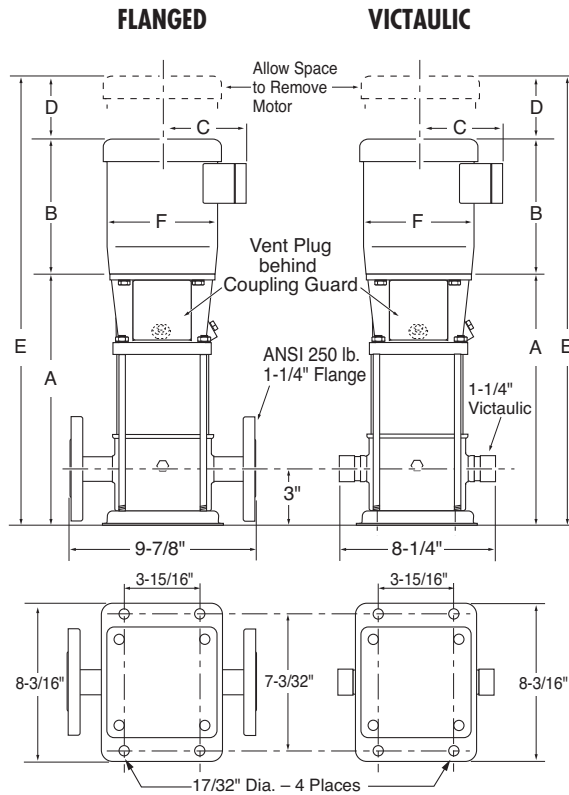
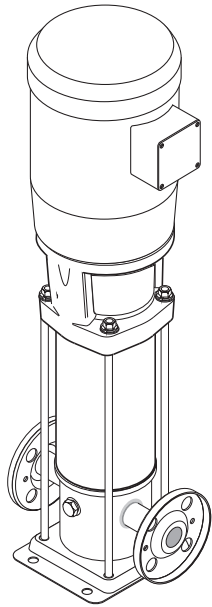

TECHNICAL INFORMATION	
MINIMUM PUMPING RATES	3 GPM
FLOW RANGE	3 – 40 GPM
MIN. SUCTION PIPE SIZES	1-1/4" Nominal Diameter, Schedule 40 Pipe
MAX. WORKING PRESSURE	360 PSI
MAX. AMBIENT TEMP.	104° F
LIQUID TEMP. RANGE	+5° F to +250° F
MOTOR OPTIONS	TEFC or ODP
CONSTRUCTION MATERIALS	See Page 16

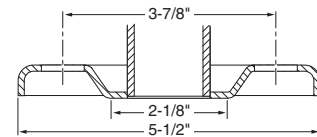

Model Number	HP	Motor S.F.	ph	Volts	Frame Size	Disc. Size	Suction Size	Dimensions in Inches*						TEFC Wt. (lbs.)	ODP Wt. (lbs.)
								A	B	C	D	E	F		
PVM(I/X)4-20/1D	0.5	1.25	1	115/208-230	56CZ	1.25	1.25	11.7	9.3	4.5	2.0	23.0	6.0	50	54
PVM(I/X)4-20/1D	0.5	1.25	3	208-230/460	56CZ	1.25	1.25	11.7	9.3	5.2	2.0	23.0	6.2	61	59
PVM(I/X)4-20D	0.75	1.25	1	115/208-230	56CZ	1.25	1.25	11.7	9.3	4.5	2.0	23.0	6.0	60	61
PVM(I/X)4-20D	0.75	1.25	3	208-230/460	56CZ	1.25	1.25	11.7	9.3	5.2	2.0	23.0	6.2	60	60
PVM(I/X)4-30D	1	1.25	1	115/208-230	56CZ	1.25	1.25	12.8	10.1	5.3	2.0	24.9	7.2	67	66
PVM(I/X)4-30D	1	1.15	3	208-230/460	56CZ	1.25	1.25	12.8	9.3	5.2	2.0	24.1	6.2	66	64
PVM(I/X)4-40D	1.5	1.25	1	115/208-230	56CZ	1.25	1.25	13.9	10.1	5.7	2.0	26.0	7.2	78	70
PVM(I/X)4-40D	1.5	1.15	3	208-230/460	56CZ	1.25	1.25	13.9	10.1	5.7	2.0	26.0	7.2	74	70
PVM(I/X)4-50D	2	1.15	1	208-230	56CZ	1.25	1.25	14.9	10.1	5.7	2.0	27.0	7.2	86	80
PVM(I/X)4-50D	2	1.15	3	208-230/460	56CZ	1.25	1.25	14.9	10.1	5.7	2.0	27.0	7.2	82	80

*Measurements represent the largest number possible for each model using standard efficiency motors.

DIMENSIONS AND SPECIFICATIONS

Date May 2013

Supersedes November 2012

316 SS CONSTRUCTION

3 THROUGH 7-1/2 HP PUMPS

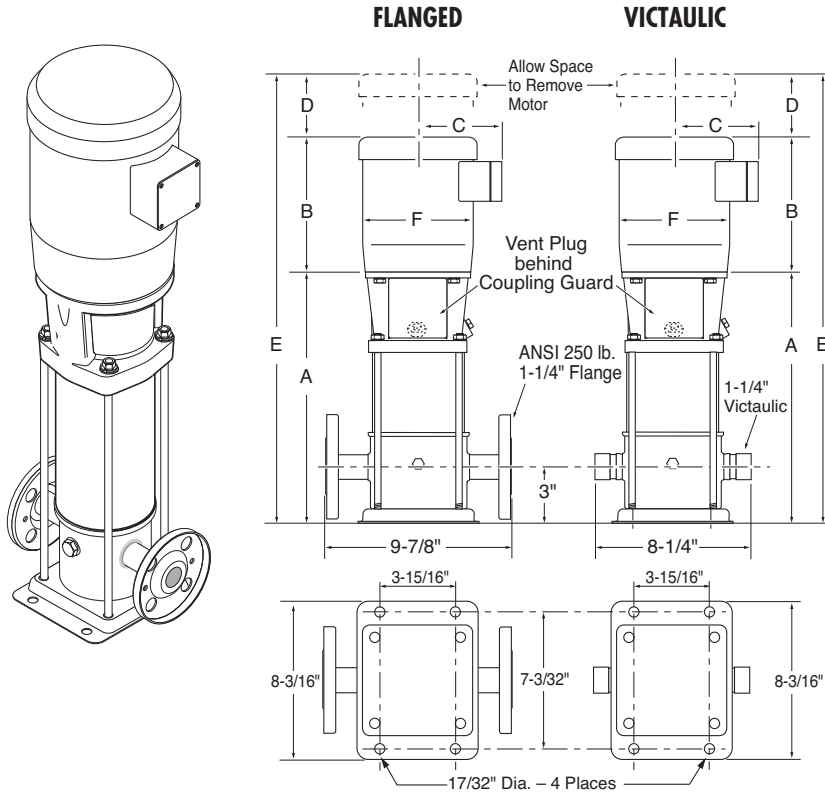

TECHNICAL INFORMATION	
MINIMUM PUMPING RATES	3 GPM
FLOW RANGE	3 – 40 GPM
MIN. SUCTION PIPE SIZES	1-1/4" Nominal Diameter, Schedule 40 Pipe
MAX. WORKING PRESSURE	360 PSI
MAX. AMBIENT TEMP.	104° F
LIQUID TEMP. RANGE	+5° F to +250° F
MOTOR OPTIONS	TEFC or ODP
CONSTRUCTION MATERIALS	See Page 16

Model Number	HP	Motor S.F.	ph	Volts	Frame Size	Disc. Size	Suction Size	Dimensions in Inches*						TEFC Wt. (lbs.)	ODP Wt. (lbs.)
								A	B	C	D	E	F		
PVM(I/X)4-60D	3	1.15	1	208-230	182TCZ	1.25	1.25	16.0	13.9	7.9	2.6	32.5	10.0	127	109
PVM(I/X)4-60D	3	1.15	3	208-230/460	182TCZ	1.25	1.25	16.0	12.6	6.9	2.6	31.2	8.6	107	104
PVM(I/X)4-80/7D	3	1.15	1	208-230	182TCZ	1.25	1.25	18.1	13.9	7.9	2.6	34.6	10.0	129	111
PVM(I/X)4-80/7D	3	1.15	3	208-230/460	182TCZ	1.25	1.25	18.1	12.6	6.9	2.6	33.3	8.6	109	106
PVM(I/X)4-80D	3	1.15	1	208-230	182TCZ	1.25	1.25	18.1	13.9	7.9	2.6	34.6	10.0	129	111
PVM(I/X)4-80D	3	1.15	3	208-230/460	182TCZ	1.25	1.25	18.1	12.6	6.9	2.6	33.3	8.6	109	106
PVM(I/X)4-90D	5	1.15	1	208-230	213TCZ	1.25	1.25	19.2	13.9	7.9	2.6	35.7	10.0	151	159
PVM(I/X)4-90D	5	1.15	3	208-230/460	184TCZ	1.25	1.25	19.2	12.6	6.9	2.6	34.4	8.6	125	118
PVM(I/X)4-100D	5	1.15	1	208-230	213TCZ	1.25	1.25	20.2	13.9	7.9	2.6	36.7	10.0	153	161
PVM(I/X)4-100D	5	1.15	3	208-230/460	184TCZ	1.25	1.25	20.2	12.6	6.9	2.6	35.4	8.6	127	120
PVM(I/X)4-110D	5	1.15	1	208-230	213TCZ	1.25	1.25	21.3	13.9	7.9	2.6	37.8	10.0	154	162
PVM(I/X)4-110D	5	1.15	3	208-230/460	184TCZ	1.25	1.25	21.3	12.6	6.9	2.6	36.5	8.6	128	121
PVM(I/X)4-120D	5	1.15	1	208-230	213TCZ	1.25	1.25	22.4	13.9	7.9	2.6	38.9	10.0	155	163
PVM(I/X)4-120D	5	1.15	3	208-230/460	184TCZ	1.25	1.25	22.4	12.6	6.9	2.6	37.6	8.6	129	122
PVM(I/X)4-130D	5	1.15	1	208-230	213TCZ	1.25	1.25	23.4	13.9	7.9	2.6	39.9	10.0	156	164
PVM(I/X)4-130D	5	1.15	3	208-230/460	184TCZ	1.25	1.25	23.4	12.6	6.9	2.6	38.6	8.6	130	123
PVM(I/X)4-140D	5	1.15	1	208-230	213TCZ	1.25	1.25	24.5	13.9	7.9	2.6	41.0	10.0	158	166
PVM(I/X)4-140D	5	1.15	3	208-230/460	184TCZ	1.25	1.25	24.5	12.6	6.9	2.6	39.7	8.6	132	125
PVM(I/X)4-150D	7.5	1.15	1	208-230	213TCZ	1.25	1.25	25.5	13.9	7.9	2.6	42.0	10.0	173	167
PVM(I/X)4-150D	7.5	1.15	3	208-230/460	213TCZ	1.25	1.25	25.5	13.9	8.1	2.6	42.0	10.3	177	177
PVM(I/X)4-160D	7.5	1.15	1	208-230	213TCZ	1.25	1.25	26.6	13.9	7.9	2.6	43.1	10.0	174	168
PVM(I/X)4-160D	7.5	1.15	3	208-230/460	213TCZ	1.25	1.25	26.6	13.9	8.1	2.6	43.1	10.3	178	178

*Measurements represent the largest number possible for each model using standard efficiency motors.

Description	Cast Iron	316 Stainless Steel	Optional Accessories
Shaft	AISI 316 SS	AISI 316 SS	
Impellers, Diffuser Chambers, Pump Sleeve, Suction Interconnector and Shaft Seal Parts	AISI 304 SS	AISI 316 SS	
Suction / Discharge	Class 30 Cast Iron	316 SS	
Motor Bracket	Class 30 Cast Iron	Class 30 CI or 316 SS	
Motor Couplings	Class 30 Cast Iron	Class 30 Cast Iron	
Intermediate Chamber	Aluminum Oxide	Aluminum Oxide	
Bearings	Ceramic	Ceramic	
Bearing Ring	Tungsten Carbide	Tungsten Carbide	
O-Rings	EPDM	EPDM	Viton® or Buna
Wear Rings	Teflon®	Teflon®	
Sleeve O-Rings	EPDM	EPDM	Viton® or Buna
Shaft Spacers	AISI 316 SS	AISI 316 SS	
Top Spring	AISI 316 SS	AISI 316 SS	
Coupling Guard	AISI 302 SS	AISI 302 SS	
Staybolts, Nuts & Washers	Zinc Plated Steel	Zinc Plated Steel	
Mechanical Seal (High Pressure)			
Stationary Face	Carbon Graphite	Carbon Graphite	
Rotating Face	Tungsten Carbide	Tungsten Carbide	
O-Rings	EPDM	EPDM	Viton® or Buna
Upper and Lower Drivers	AISI 316 SS	AISI 316 SS	
Spring	AISI 316 SS	AISI 316 SS	

NOMINAL RPM: 3450

BASED ON FRESH WATER @ 68° F

MAXIMUM WORKING PRESSURE: 360 PSI

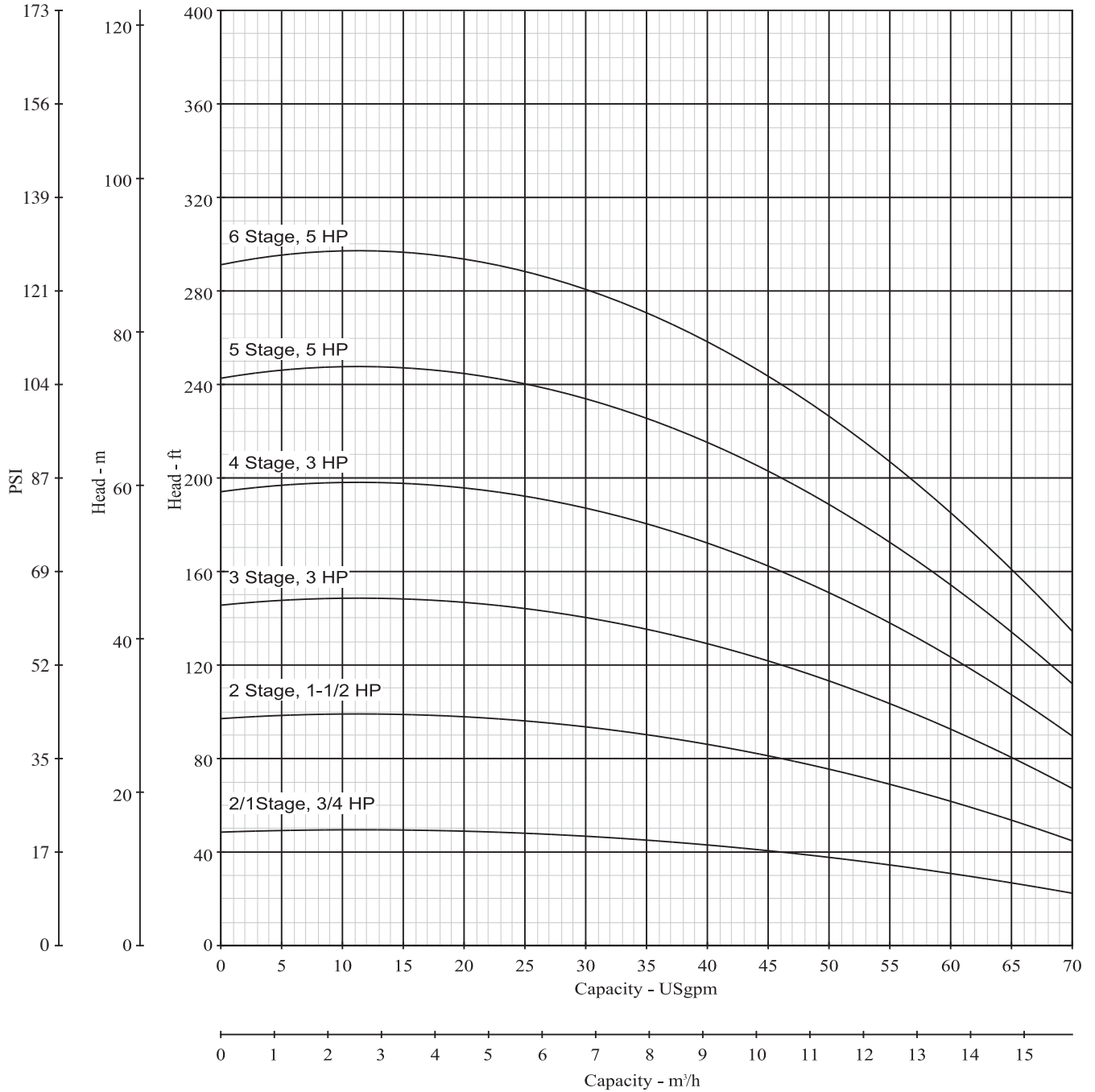

AURORA® PVM(X)8 SERIES

PERFORMANCE CURVES

NOMINAL RPM: 3450 **BASED ON FRESH WATER @ 68° F** **MAXIMUM WORKING PRESSURE: 360 PSI**

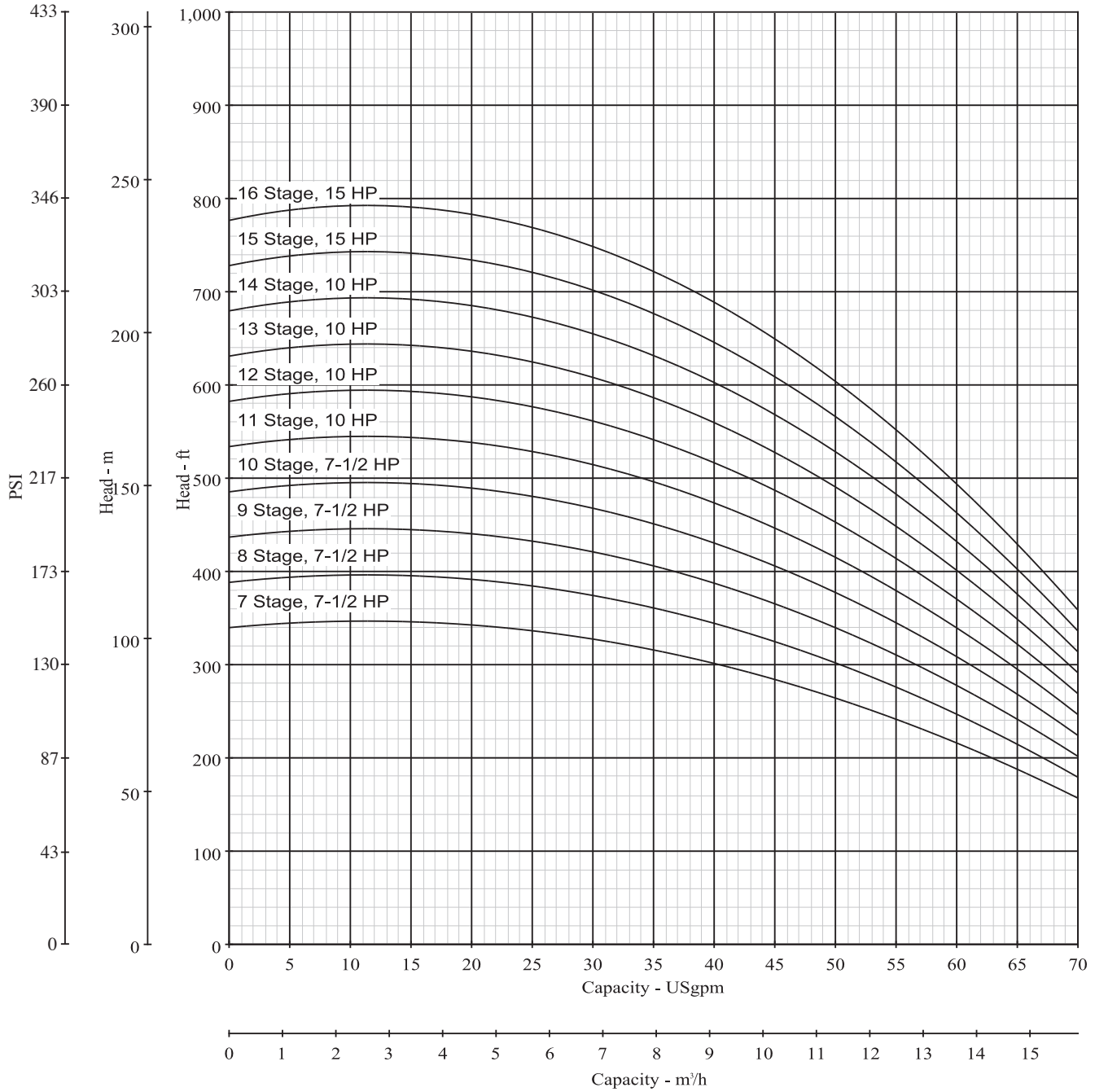

NOMINAL RPM: 3450 **BASED ON FRESH WATER @ 68° F** **MAXIMUM WORKING PRESSURE: 360 PSI**

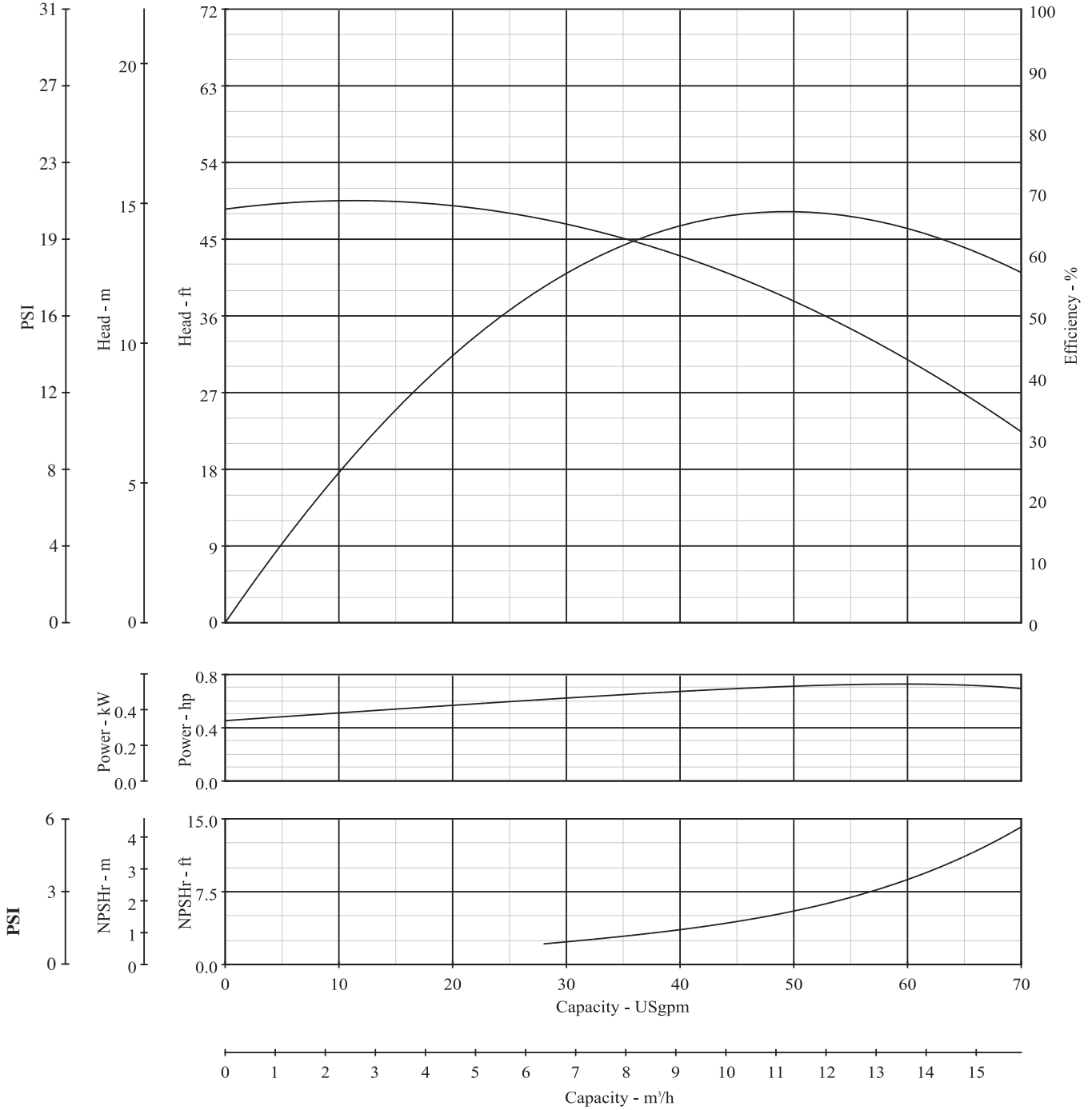

AURORA® PVM8 SERIES

DIMENSIONS AND SPECIFICATIONS

CAST IRON CONSTRUCTION

3/4 THROUGH 5 HP PUMPS

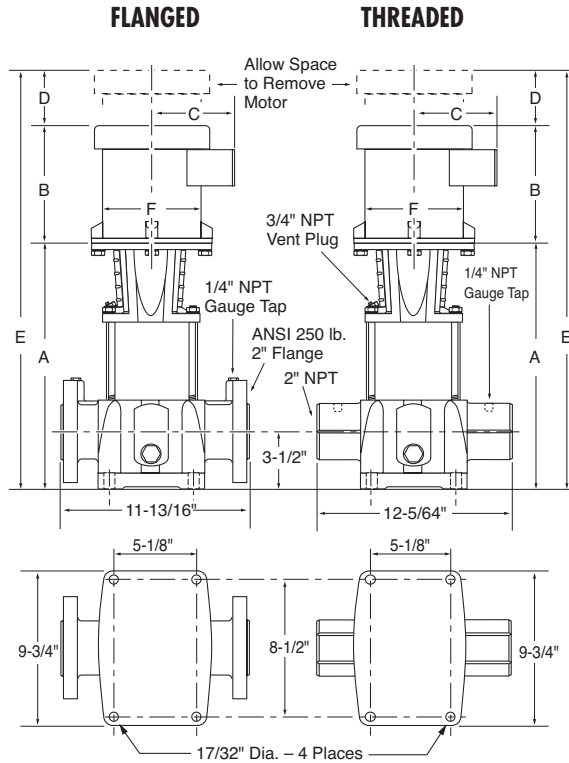
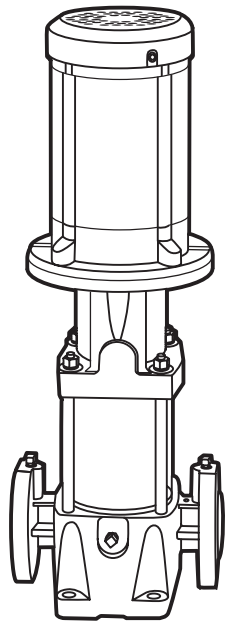

TECHNICAL INFORMATION	
MINIMUM PUMPING RATES	5.3 GPM
FLOW RANGE	5.3 – 65 GPM
MIN. SUCTION PIPE SIZES	2" Nominal Diameter, Schedule 40 Pipe
MAX. WORKING PRESSURE	360 PSI
MAX. AMBIENT TEMP.	104° F
LIQUID TEMP. RANGE	+5° F to +250° F
MOTOR OPTIONS	TEFC or ODP
CONSTRUCTION MATERIALS	See Page 29

2" ANSI. 250 lb. 8-Bolt Flange

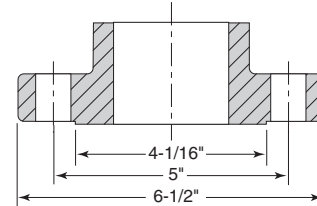

Model Number	HP	Motor S.F.	ph	Volts	Frame Size	Disc. Size	Suction Size	Dimensions in Inches*						TEFC Wt. (lbs.)	ODP Wt. (lbs.)
								A	B	C	D	E	F		
PVM8-20/1D	0.75	1.25	1	115/208-230	56CZ	2	2	14.1	9.3	4.5	2.0	25.4	6.0	93	94
PVM8-20/1D	0.75	1.25	3	208-230/460	56CZ	2	2	14.1	9.3	4.5	2.0	25.4	6.0	93	93
PVM8-20D	1.5	1.25	1	115/208-230	56CZ	2	2	15.2	10.1	5.7	2.0	27.3	7.2	111	103
PVM8-20D	1.5	1.15	3	208-230/460	56CZ	2	2	15.2	10.1	5.7	2.0	27.3	7.2	107	103
PVM8-30D	3	1.15	1	208-230	182TCZ	2	2	16.4	13.9	7.9	2.6	32.9	10.0	169	151
PVM8-30D	3	1.15	3	208-230/460	182TCZ	2	2	16.4	12.6	6.9	2.6	31.6	8.6	149	146
PVM8-40D	3	1.15	1	208-230	182TCZ	2	2	17.6	13.9	7.9	2.6	34.1	10.0	171	153
PVM8-40D	3	1.15	3	208-230/460	182TCZ	2	2	17.6	12.6	6.9	2.6	32.8	8.6	151	148
PVM8-50D	5	1.15	1	208-230	213TCZ	2	2	18.8	13.9	7.9	2.6	35.3	10.0	193	201
PVM8-50D	5	1.15	3	208-230/460	184TCZ	2	2	18.8	12.6	6.9	2.6	34.0	8.6	167	160
PVM8-60D	5	1.15	1	208-230	213TCZ	2	2	20.0	13.9	7.9	2.6	36.5	10.0	195	203
PVM8-60D	5	1.15	3	208-230/460	184TCZ	2	2	20.0	12.6	6.9	2.6	35.2	8.6	169	162
PVM8-70D	7.5	1.15	1	208-230	213TCZ	2	2	21.1	13.9	7.9	2.6	37.6	10.0	210	204
PVM8-70D	7.5	1.15	3	208-230/460	213TCZ	2	2	21.1	13.9	8.1	2.6	37.6	10.3	214	214

*Measurements represent the largest number possible for each model using standard efficiency motors.

DIMENSIONS AND SPECIFICATIONS

Date May 2013

Supersedes November 2012

CAST IRON CONSTRUCTION

7-1/2 THROUGH 15 HP PUMPS

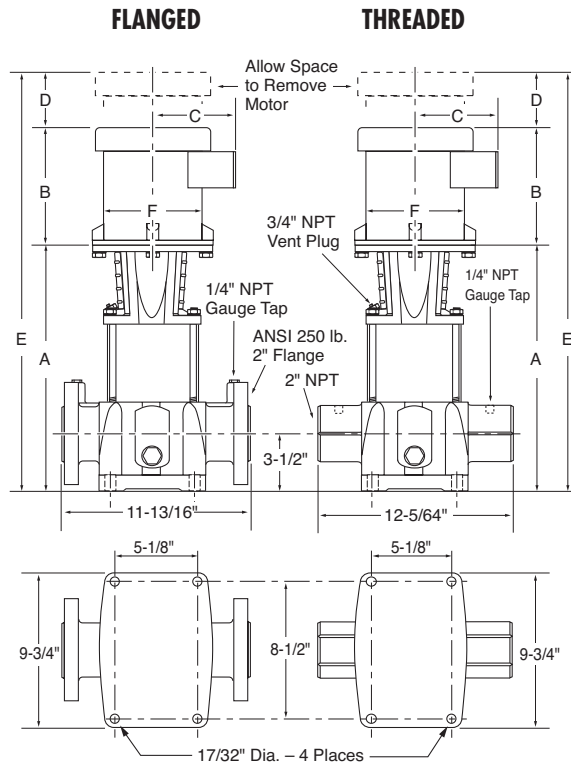
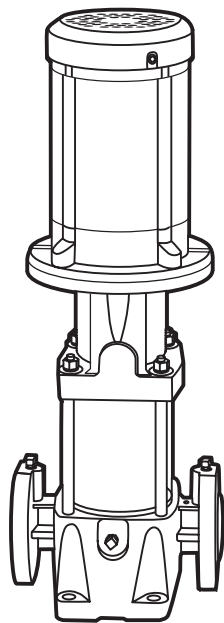

TECHNICAL INFORMATION	
MINIMUM PUMPING RATES	5.3 GPM
FLOW RANGE	5.3 – 65 GPM
MIN. SUCTION PIPE SIZES	2" Nominal Diameter, Schedule 40 Pipe
MAX. WORKING PRESSURE	360 PSI
MAX. AMBIENT TEMP.	104° F
LIQUID TEMP. RANGE	+5° F to +250° F
MOTOR OPTIONS	TEFC or ODP
CONSTRUCTION MATERIALS	See Page 29

2" ANSI. 250 lb. 8-Bolt Flange

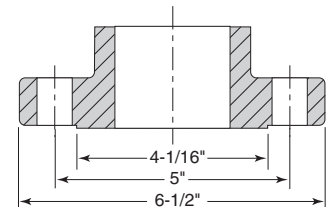

Model Number	HP	Motor S.F.	ph	Volts	Frame Size	Disc. Size	Suction Size	Dimensions in Inches*						TEFC Wt. (lbs.)	ODP Wt. (lbs.)
								A	B	C	D	E	F		
PVM8-80D	7.5	1.15	1	208-230	213TCZ	2	2	22.3	13.9	7.9	2.6	38.8	10.0	212	206
PVM8-80D	7.5	1.15	3	208-230/460	213TCZ	2	2	22.3	13.9	8.1	2.6	38.8	10.3	216	216
PVM8-90D	7.5	1.15	1	208-230	213TCZ	2	2	23.5	13.9	7.9	2.6	40.0	10.0	213	207
PVM8-90D	7.5	1.15	3	208-230/460	213TCZ	2	2	23.5	13.9	8.1	2.6	40.0	10.3	217	217
PVM8-100D	7.5	1.15	1	208-230	213TCZ	2	2	24.7	13.9	7.9	2.6	41.2	10.0	215	209
PVM8-100D	7.5	1.15	3	208-230/460	213TCZ	2	2	24.7	13.9	8.1	2.6	41.2	10.3	219	219
PVM8-110D	10	1.15	1	208-230	215TCZ	2	2	25.9	13.9	7.9	3.1	42.9	10.0	248	233
PVM8-110D	10	1.15	3	208-230/460	215TCZ	2	2	25.9	14.2	8.1	3.1	43.2	10.3	245	225
PVM8-120D	10	1.15	1	208-230	215TCZ	2	2	27.0	13.9	7.9	3.1	44.0	10.0	250	235
PVM8-120D	10	1.15	3	208-230/460	215TCZ	2	2	27.0	14.2	8.1	3.1	44.3	10.3	247	227
PVM8-130D	10	1.15	1	208-230	215TCZ	2	2	28.2	13.9	7.9	3.1	45.2	10.0	251	236
PVM8-130D	10	1.15	3	208-230/460	215TCZ	2	2	28.2	14.2	8.1	3.1	45.5	10.3	248	228
PVM8-140D	10	1.15	1	208-230	215TCZ	2	2	29.4	13.9	7.9	3.1	46.4	10.0	253	238
PVM8-140D	10	1.15	3	208-230/460	215TCZ	2	2	29.4	14.2	8.1	3.1	46.7	10.3	250	230
PVM8-160D	15	1.15	3	230/460	215TCZ	2	2	32.3	20.0	9.5	4.0	56.3	12.9	342	233
PVM8-160D	15	1.15	3	208-230/460	215TCZ	2	2	32.3	20.0	9.5	4.0	56.3	12.9	342	233

*Measurements represent the largest number possible for each model using standard efficiency motors.

AURORA® PVM(I/X)8 SERIES

DIMENSIONS AND SPECIFICATIONS

316 SS CONSTRUCTION

3/4 THROUGH 5 HP PUMPS

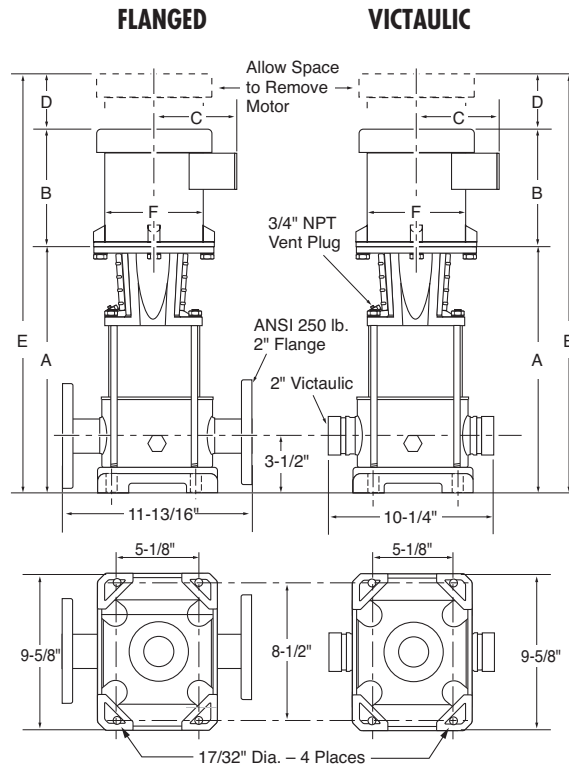
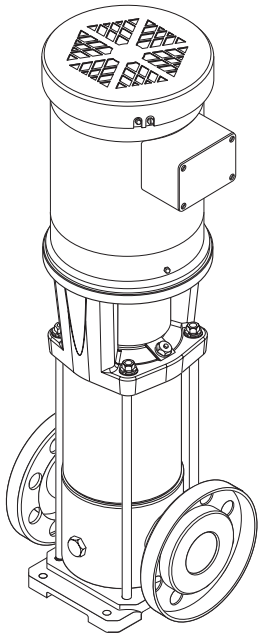

TECHNICAL INFORMATION	
MINIMUM PUMPING RATES	5.3 GPM
FLOW RANGE	5.3 – 65 GPM
MIN. SUCTION PIPE SIZES	2" Nominal Diameter, Schedule 40 Pipe
MAX. WORKING PRESSURE	360 PSI
MAX. AMBIENT TEMP.	104° F
LIQUID TEMP. RANGE	+5° F to +250° F
MOTOR OPTIONS	TEFC or ODP
CONSTRUCTION MATERIALS	See Page 29

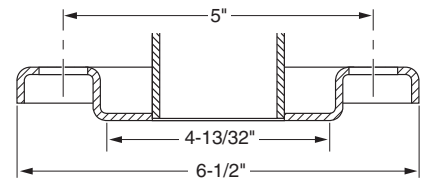

Model Number	HP	Motor S.F.	ph	Volts	Frame Size	Disc. Size	Suction Size	Dimensions in Inches*						TEFC Wt. (lbs.)	ODP Wt. (lbs.)
								A	B	C	D	E	F		
PVM(I/X)8-20/1D	0.75	1.25	1	115/208-230	56CZ	2	2	14.1	9.3	4.5	2.0	25.4	6.0	71	72
PVM(I/X)8-20/1D	0.75	1.25	3	208-230/460	56CZ	2	2	14.1	9.3	4.5	2.0	25.4	6.0	71	71
PVM(I/X)8-20D	1.5	1.25	1	115/208-230	56CZ	2	2	15.2	10.1	5.7	2.0	27.3	7.2	88	80
PVM(I/X)8-20D	1.5	1.15	3	208-230/460	56CZ	2	2	15.2	10.1	5.7	2.0	27.3	7.2	84	80
PVM(I/X)8-30D	3	1.15	1	208-230	182TCZ	2	2	16.4	13.9	7.9	2.6	32.9	10.0	147	129
PVM(I/X)8-30D	3	1.15	3	208-230/460	182TCZ	2	2	16.4	12.6	6.9	2.6	31.6	8.6	127	124
PVM(I/X)8-40D	3	1.15	1	208-230	182TCZ	2	2	17.6	13.9	7.9	2.6	34.1	10.0	148	130
PVM(I/X)8-40D	3	1.15	3	208-230/460	182TCZ	2	2	17.6	12.6	6.9	2.6	32.8	8.6	128	125
PVM(I/X)8-50D	5	1.15	1	208-230	213TCZ	2	2	18.8	13.9	7.9	2.6	35.3	10.0	171	179
PVM(I/X)8-50D	5	1.15	3	208-230/460	184TCZ	2	2	18.8	12.6	6.9	2.6	34.0	8.6	145	138
PVM(I/X)8-60D	5	1.15	1	208-230	213TCZ	2	2	20.0	13.9	7.9	2.6	36.5	10.0	172	180
PVM(I/X)8-60D	5	1.15	3	208-230/460	184TCZ	2	2	20.0	12.6	6.9	2.6	35.2	8.6	146	139
PVM(I/X)8-70D	7.5	1.15	1	208-230	213TCZ	2	2	21.1	13.9	7.9	2.6	37.6	10.0	188	182
PVM(I/X)8-70D	7.5	1.15	3	208-230/460	213TCZ	2	2	21.1	13.9	8.1	2.6	37.6	10.3	192	192

*Measurements represent the largest number possible for each model using standard efficiency motors.

DIMENSIONS AND SPECIFICATIONS

316 SS CONSTRUCTION

7-1/2 THROUGH 15 HP PUMPS

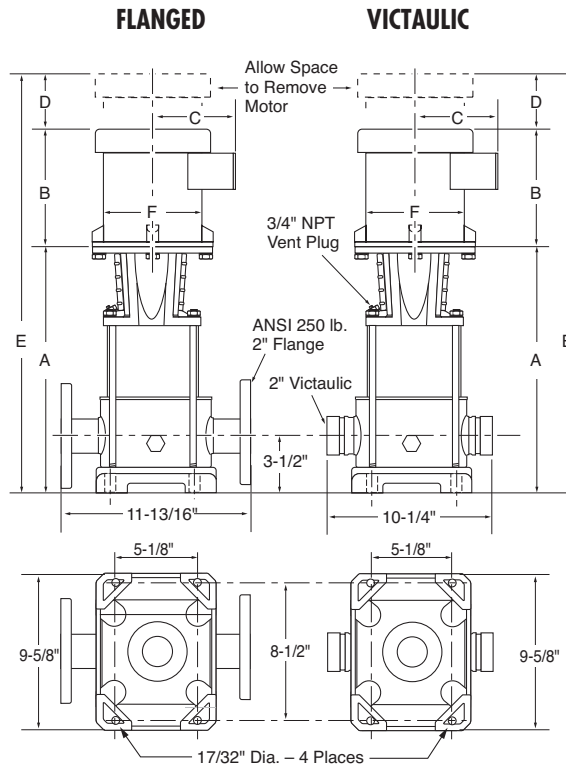
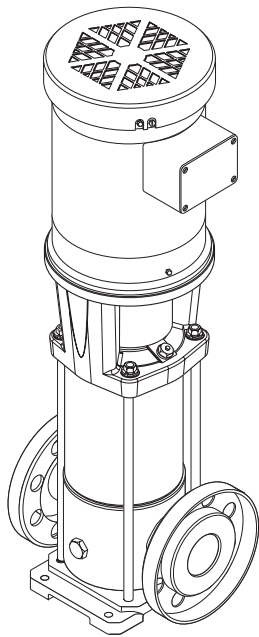

TECHNICAL INFORMATION	
MINIMUM PUMPING RATES	5.3 GPM
FLOW RANGE	5.3 – 65 GPM
MIN. SUCTION PIPE SIZES	2" Nominal Diameter, Schedule 40 Pipe
MAX. WORKING PRESSURE	360 PSI
MAX. AMBIENT TEMP.	104° F
LIQUID TEMP. RANGE	+5° F to +250° F
MOTOR OPTIONS	TEFC or ODP
CONSTRUCTION MATERIALS	See Page 29

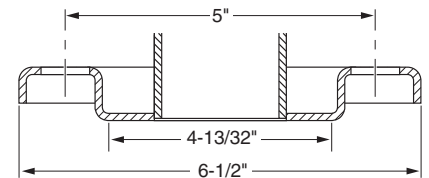

Model Number	HP	Motor S.F.	ph	Volts	Frame Size	Disc. Size	Suction Size	Dimensions in Inches*						TEFC Wt. (lbs.)	ODP Wt. (lbs.)
								A	B	C	D	E	F		
PVM(I/X)8-80D	7.5	1.15	1	208-230	213TCZ	2	2	22.3	13.9	7.9	2.6	38.8	10.0	189	183
PVM(I/X)8-80D	7.5	1.15	3	208-230/460	213TCZ	2	2	22.3	13.9	8.1	2.6	38.8	10.3	193	193
PVM(I/X)8-90D	7.5	1.15	1	208-230	213TCZ	2	2	23.5	13.9	7.9	2.6	40.0	10.0	191	185
PVM(I/X)8-90D	7.5	1.15	3	208-230/460	213TCZ	2	2	23.5	13.9	8.1	2.6	40.0	10.3	195	195
PVM(I/X)8-100D	7.5	1.15	1	208-230	213TCZ	2	2	24.7	13.9	7.9	2.6	41.2	10.0	192	186
PVM(I/X)8-100D	7.5	1.15	3	208-230/460	213TCZ	2	2	24.7	13.9	8.1	2.6	41.2	10.3	196	196
PVM(I/X)8-110D	10	1.15	1	208-230	215TCZ	2	2	25.9	13.9	7.9	3.1	42.9	10.0	226	211
PVM(I/X)8-110D	10	1.15	3	208-230/460	215TCZ	2	2	25.9	14.2	8.1	3.1	43.2	10.3	223	203
PVM(I/X)8-120D	10	1.15	1	208-230	215TCZ	2	2	27.0	13.9	7.9	3.1	44.0	10.0	227	212
PVM(I/X)8-120D	10	1.15	3	208-230/460	215TCZ	2	2	27.0	14.2	8.1	3.1	44.3	10.3	224	204
PVM(I/X)8-130D	10	1.15	1	208-230	215TCZ	2	2	28.2	13.9	7.9	3.1	45.2	10.0	229	214
PVM(I/X)8-130D	10	1.15	3	208-230/460	215TCZ	2	2	28.2	14.2	8.1	3.1	45.5	10.3	226	206
PVM(I/X)8-140D	10	1.15	1	208-230	215TCZ	2	2	29.4	13.9	7.9	3.1	46.4	10.0	230	215
PVM(I/X)8-140D	10	1.15	3	208-230/460	215TCZ	2	2	29.4	14.2	8.1	3.1	46.7	10.3	227	207
PVM(I/X)8-150D	15	1.15	3	230/460	215TCZ	2	2	31.1	20.0	9.5	4.0	55.1	12.9	318	209
PVM(I/X)8-160D	15	1.15	3	208-230/460	215TCZ	2	2	32.3	20.0	9.5	4.0	56.3	12.9	319	210

*Measurements represent the largest number possible for each model using standard efficiency motors.

AURORA® PVM(X)16 SERIES

PERFORMANCE CURVES

NOMINAL RPM: 3450 **BASED ON FRESH WATER @ 68° F** **MAXIMUM WORKING PRESSURE: 360 PSI**

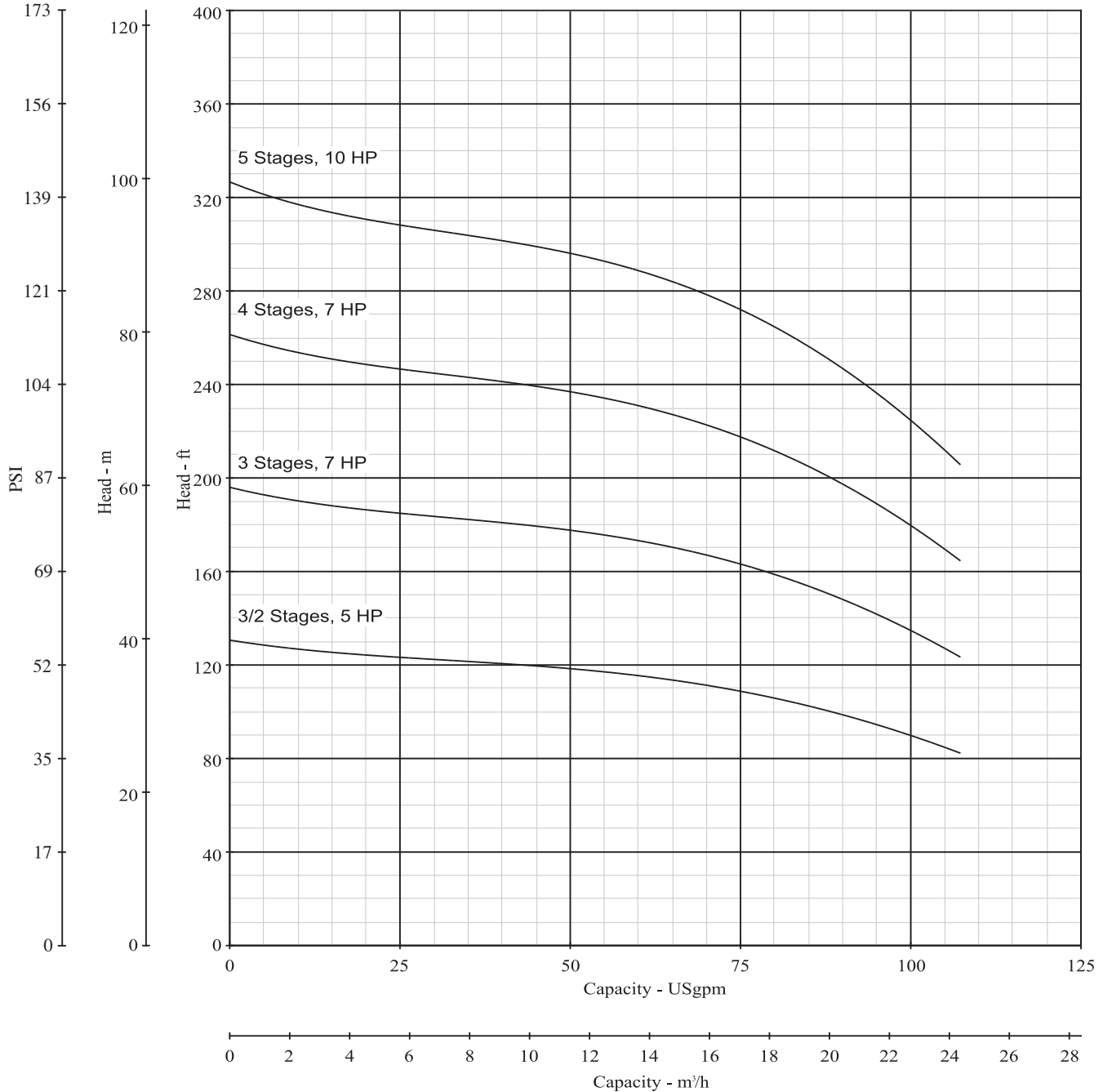

NOMINAL RPM: 3450	BASED ON FRESH WATER @ 68° F	MAXIMUM WORKING PRESSURE: 360 PSI
--------------------------	-------------------------------------	--

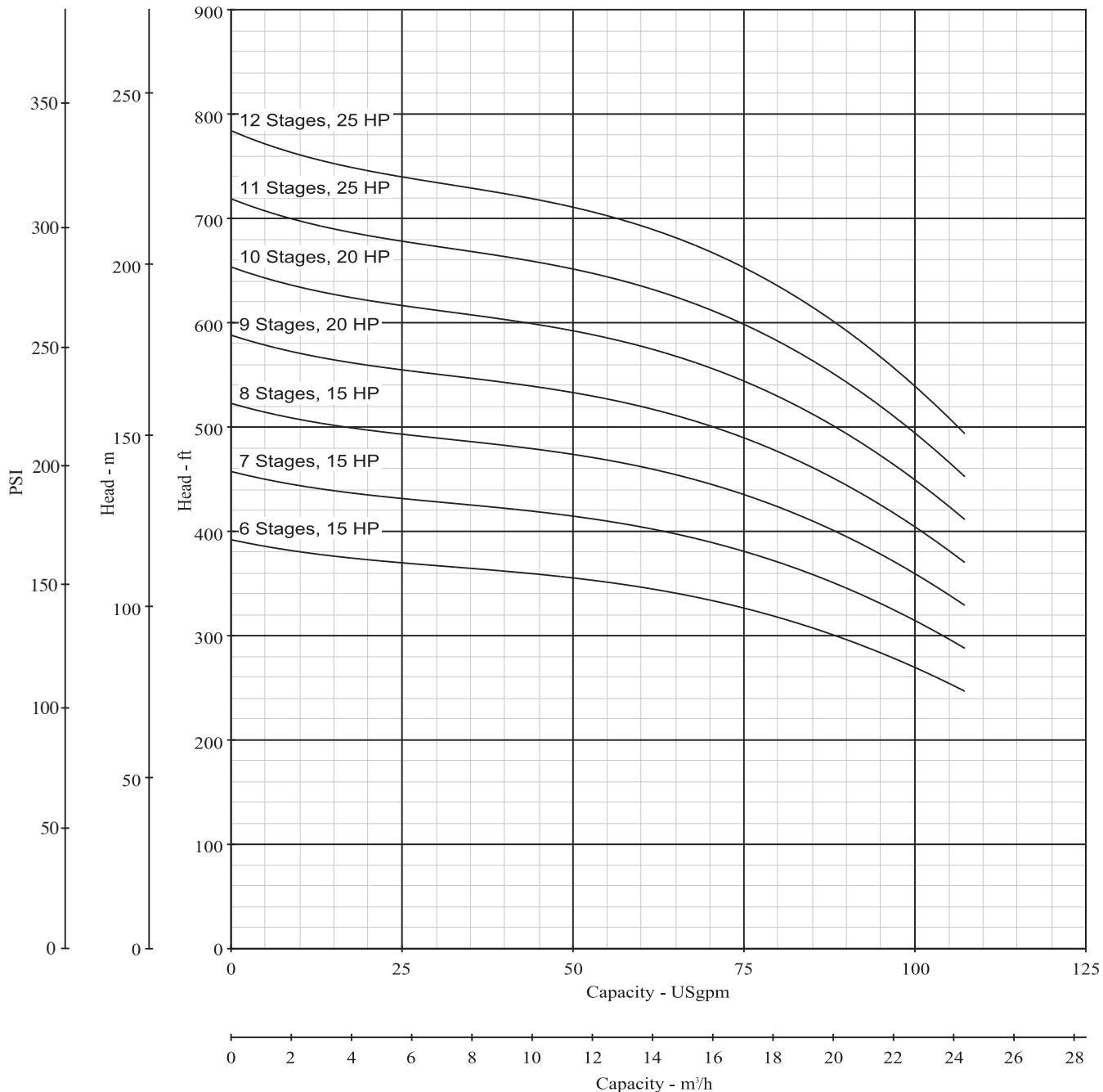

AURORA® PVM(X)16 SERIES

SINGLE STAGE PERFORMANCE DATA

NOMINAL RPM: 3450 **BASED ON FRESH WATER @ 68° F** **MAXIMUM WORKING PRESSURE: 360 PSI**

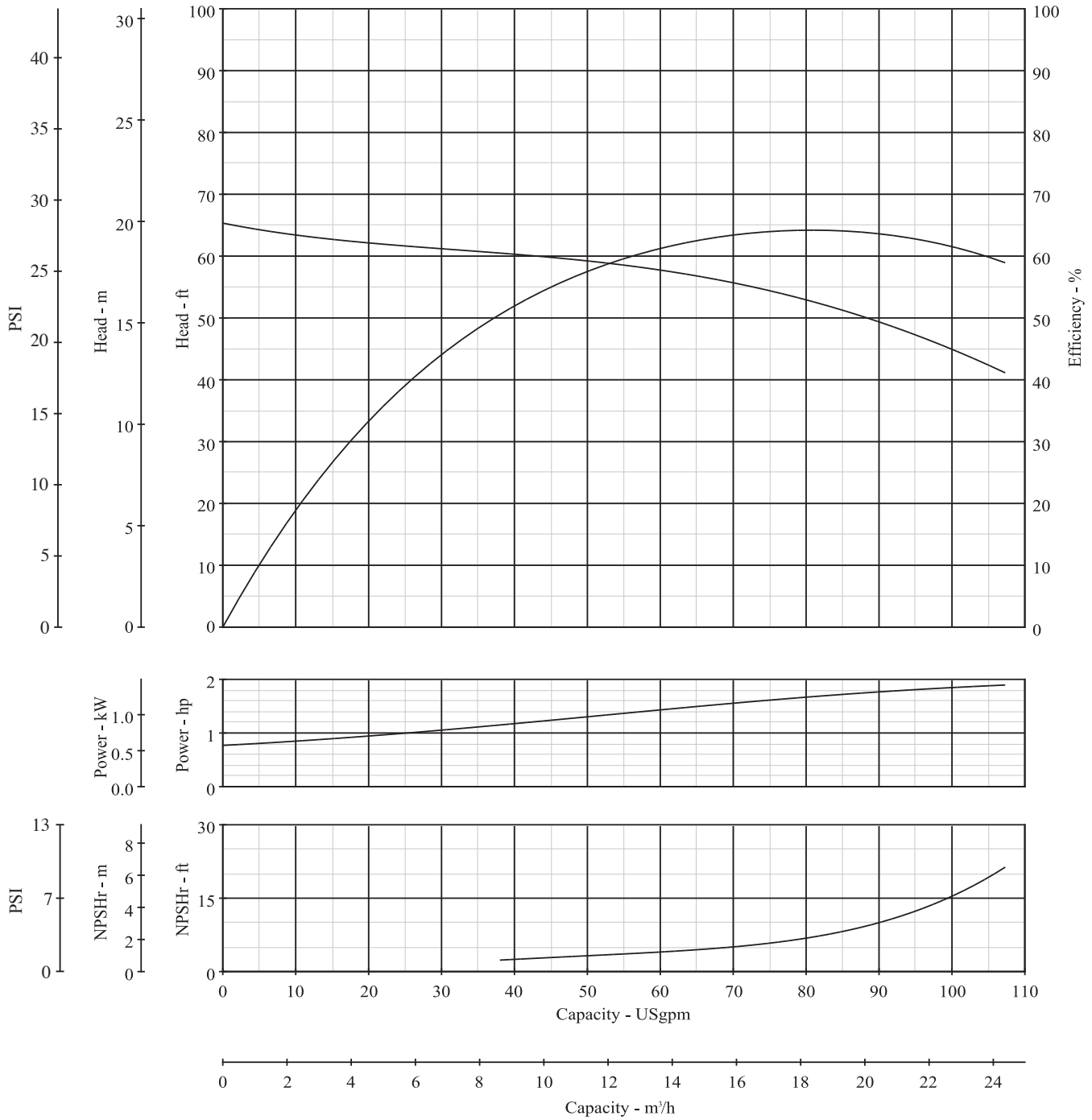

DIMENSIONS AND SPECIFICATIONS

CAST IRON CONSTRUCTION

5 THROUGH 25 HP PUMPS

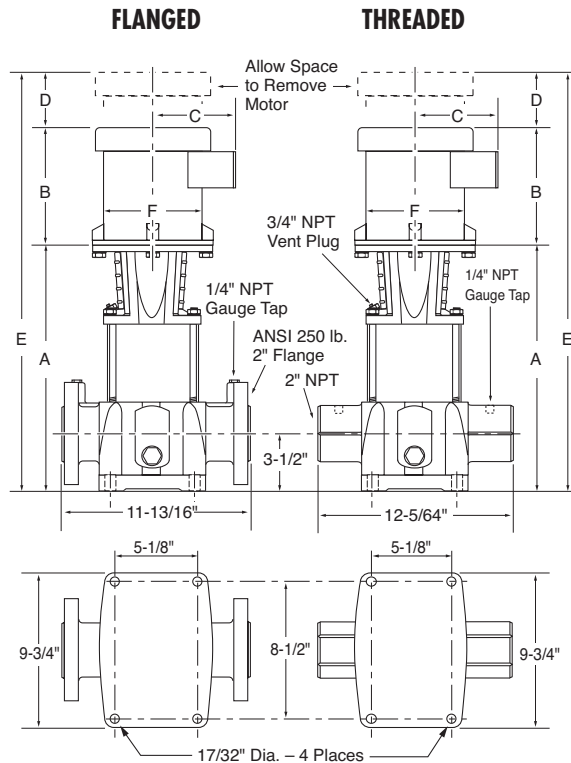
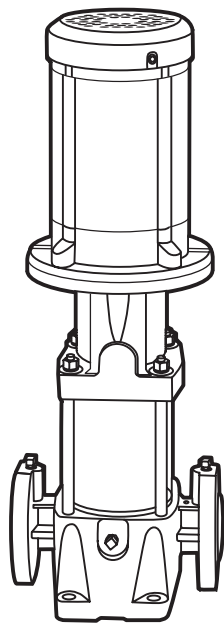

TECHNICAL INFORMATION	
MINIMUM PUMPING RATES	8.5 GPM
FLOW RANGE	8.5 – 105 GPM
MIN. SUCTION PIPE SIZES	2" Nominal Diameter, Schedule 40 Pipe
MAX. WORKING PRESSURE	360 PSI
MAX. AMBIENT TEMP.	104° F
LIQUID TEMP. RANGE	+5° F to +250° F
MOTOR OPTIONS	TEFC or ODP
CONSTRUCTION MATERIALS	See Page 29

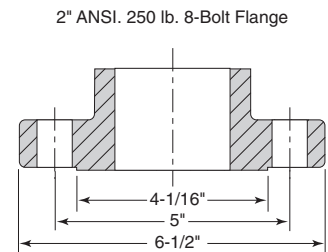

Model Number	HP	Motor S.F.	ph	Volts	Frame Size	Disc. Size	Suction Size	Dimensions in Inches*						TEFC Wt. (lbs.)	ODP Wt. (lbs.)
								A	B	C	D	E	F		
PVM16-30/2D	5	1.15	1	208-230	213TCZ	2	2	15.8	13.9	7.9	2.6	32.3	10.0	189	197
PVM16-30/2D	5	1.15	3	208-230/460	184TCZ	2	2	15.8	12.6	6.9	2.6	31.0	8.6	163	156
PVM16-30D	7.5	1.15	1	208-230	213TCZ	2	2	17.6	13.9	7.9	2.6	34.1	10.0	205	199
PVM16-30D	7.5	1.15	3	208-230/460	213TCZ	2	2	17.6	13.9	8.1	2.6	34.1	10.3	209	209
PVM16-40D	7.5	1.15	1	208-230	213TCZ	2	2	19.4	13.9	7.9	2.6	35.9	10.0	206	200
PVM16-40D	7.5	1.15	3	208-230/460	213TCZ	2	2	19.4	13.9	8.1	2.6	35.9	10.3	210	210
PVM16-50D	10	1.15	1	208-230	215TCZ	2	2	21.1	13.9	7.9	3.1	38.1	10.0	240	225
PVM16-50D	10	1.15	3	208-230/460	215TCZ	2	2	21.1	14.2	8.1	3.1	38.4	10.3	237	217
PVM16-60D	15	1.15	3	208-230/460	254TCZ	2	2	23.4	20.0	9.5	4.0	47.4	12.9	328	219
PVM16-70D	15	1.15	3	208-230/460	254TCZ	2	2	25.2	20.0	9.5	4.0	49.2	12.9	329	220
PVM16-80D	15	1.15	3	208-230/460	254TCZ	2	2	27.0	20.0	9.5	4.0	51.0	12.9	331	222
PVM16-90D	20	1.15	3	230/460	254TCZ	2	2	28.7	16.9	9.2	3.8	49.4	11.5	376	321
PVM16-100D	20	1.15	3	230/460	254TCZ	2	2	30.5	16.9	9.2	3.8	51.2	11.5	377	322
PVM16-110D	25	1.15	3	230/460	284TCZ	2	2	31.6	20.0	9.5	3.0	54.6	13.3	395	340
PVM16-120D	25	1.15	3	230/460	284TCZ	2	2	33.4	20.0	9.5	3.0	56.4	13.3	397	342

*Measurements represent the largest number possible for each model using standard efficiency motors.

AURORA® PVM(I/X)16 SERIES

DIMENSIONS AND SPECIFICATIONS

316 SS CONSTRUCTION

5 THROUGH 25 HP PUMPS

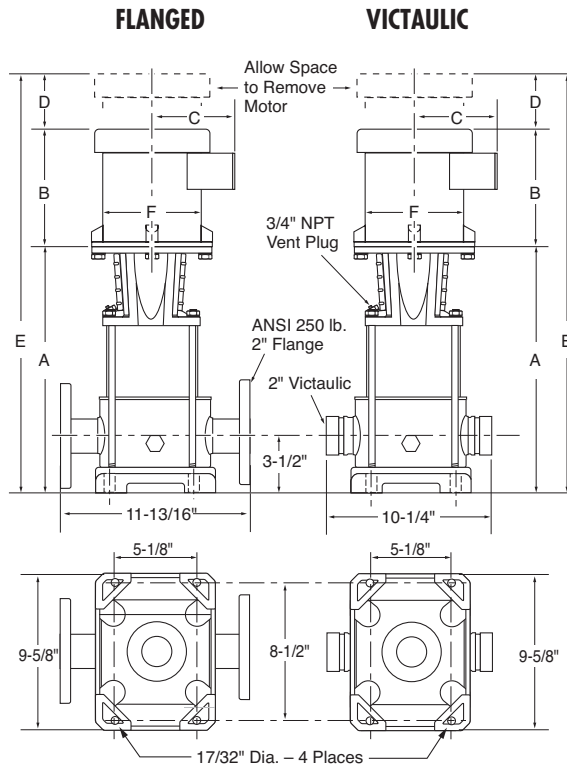
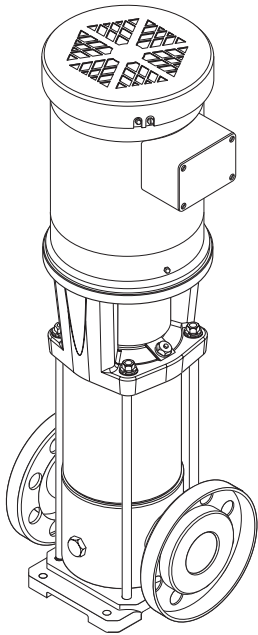

TECHNICAL INFORMATION	
MINIMUM PUMPING RATES	8.5 GPM
FLOW RANGE	8.5 – 105 GPM
MIN. SUCTION PIPE SIZES	2" Nominal Diameter, Schedule 40 Pipe
MAX. WORKING PRESSURE	360 PSI
MAX. AMBIENT TEMP.	104° F
LIQUID TEMP. RANGE	+5° F to +250° F
MOTOR OPTIONS	TEFC or ODP
CONSTRUCTION MATERIALS	See Page 29

Model Number	HP	Motor S.F.	ph	Volts	Frame Size	Disc. Size	Suction Size	Dimensions in Inches*						TEFC Wt. (lbs.)	ODP Wt. (lbs.)
								A	B	C	D	E	F		
PVM(I/X)16-30/2D	5	1.15	1	208-230	213TCZ	2	2	15.8	13.9	7.9	2.6	32.3	10.0	167	175
PVM(I/X)16-30/2D	5	1.15	3	208-230/460	184TCZ	2	2	15.8	12.6	6.9	2.6	31.0	8.6	141	134
PVM(I/X)16-30D	7.5	1.15	1	208-230	213TCZ	2	2	17.6	13.9	7.9	2.6	34.1	10.0	182	176
PVM(I/X)16-30D	7.5	1.15	3	208-230/460	213TCZ	2	2	17.6	13.9	8.1	2.6	34.1	10.3	186	186
PVM(I/X)16-40D	7.5	1.15	1	208-230	213TCZ	2	2	19.4	13.9	7.9	2.6	35.9	10.0	184	178
PVM(I/X)16-40D	7.5	1.15	3	208-230/460	213TCZ	2	2	19.4	13.9	8.1	2.6	35.9	10.3	188	188
PVM(I/X)16-50D	10	1.15	1	208-230	215TCZ	2	2	21.1	13.9	7.9	3.1	38.1	10.0	218	203
PVM(I/X)16-50D	10	1.15	3	208-230/460	215TCZ	2	2	21.1	14.2	8.1	3.1	38.4	10.3	215	195
PVM(I/X)16-60D	15	1.15	3	208-230/460	254TCZ	2	2	23.4	20.0	9.5	4.0	47.4	12.9	305	196
PVM(I/X)16-70D	15	1.15	3	208-230/460	254TCZ	2	2	25.2	20.0	9.5	4.0	49.2	12.9	307	198
PVM(I/X)16-80D	15	1.15	3	208-230/460	254TCZ	2	2	27.0	20.0	9.5	4.0	51.0	12.9	309	200
PVM(I/X)16-90D	20	1.15	3	230/460	254TCZ	2	2	28.7	16.9	9.2	3.8	49.4	11.5	353	298
PVM(I/X)16-100D	20	1.15	3	230/460	254TCZ	2	2	30.5	16.9	9.2	3.8	51.2	11.5	355	300
PVM(I/X)16-110D	25	1.15	3	230/460	284TCZ	2	2	31.6	20.0	9.5	3.0	54.6	13.3	372	317
PVM(I/X)16-120D	25	1.15	3	230/460	284TCZ	2	2	33.4	20.0	9.5	3.0	56.4	13.3	374	319

*Measurements represent the largest number possible for each model using standard efficiency motors.

Description	Cast Iron	316 Stainless Steel	Optional Accessories
Shaft	AISI 431 SS	AISI 316 SS	
Impellers, Diffuser Chambers, Pump Sleeve, Suction Interconnector and Shaft Seal Parts	AISI 304 SS	AISI 316 SS	
Suction / Discharge	Class 30 Cast Iron	316 SS	
Motor Bracket	Class 30 Cast Iron	Class 30 CI or 316 SS	
Motor Couplings	Class 30 Cast Iron	Class 30 Cast Iron	
Intermediate Chamber	Aluminum Oxide	Aluminum Oxide	
Bearings	Ceramic	Ceramic	
Bearing Ring	Tungsten Carbide	Tungsten Carbide	
O-Rings	EPDM	EPDM	Viton® or Buna-N
Wear Rings	Teflon®	Teflon®	
Sleeve O-Rings	EPDM	EPDM	Viton® or Buna-N
Shaft Spacers	AISI 316 SS	AISI 316 SS	
Top Spring	AISI 316 SS	AISI 316 SS	
Coupling Guard	AISI 302 SS	AISI 302 SS	
Staybolts, Nuts & Washers	Zinc Plated Steel	Zinc Plated Steel	
Mechanical Seal (High Pressure)			
Stationary Face	Carbon Graphite	Carbon Graphite	
Rotating Face	Tungsten Carbide	Tungsten Carbide	
O-Rings	EPDM	EPDM	Viton® or Buna-N
Upper and Lower Drivers	AISI 316 SS	AISI 316 SS	
Spring	AISI 316 SS	AISI 316 SS	

AURORA® PVM32 SERIES

PERFORMANCE CURVES

NOMINAL RPM: 3450 (*3520) **BASED ON FRESH WATER @ 68° F** **MAXIMUM WORKING PRESSURE: 435 PSI**

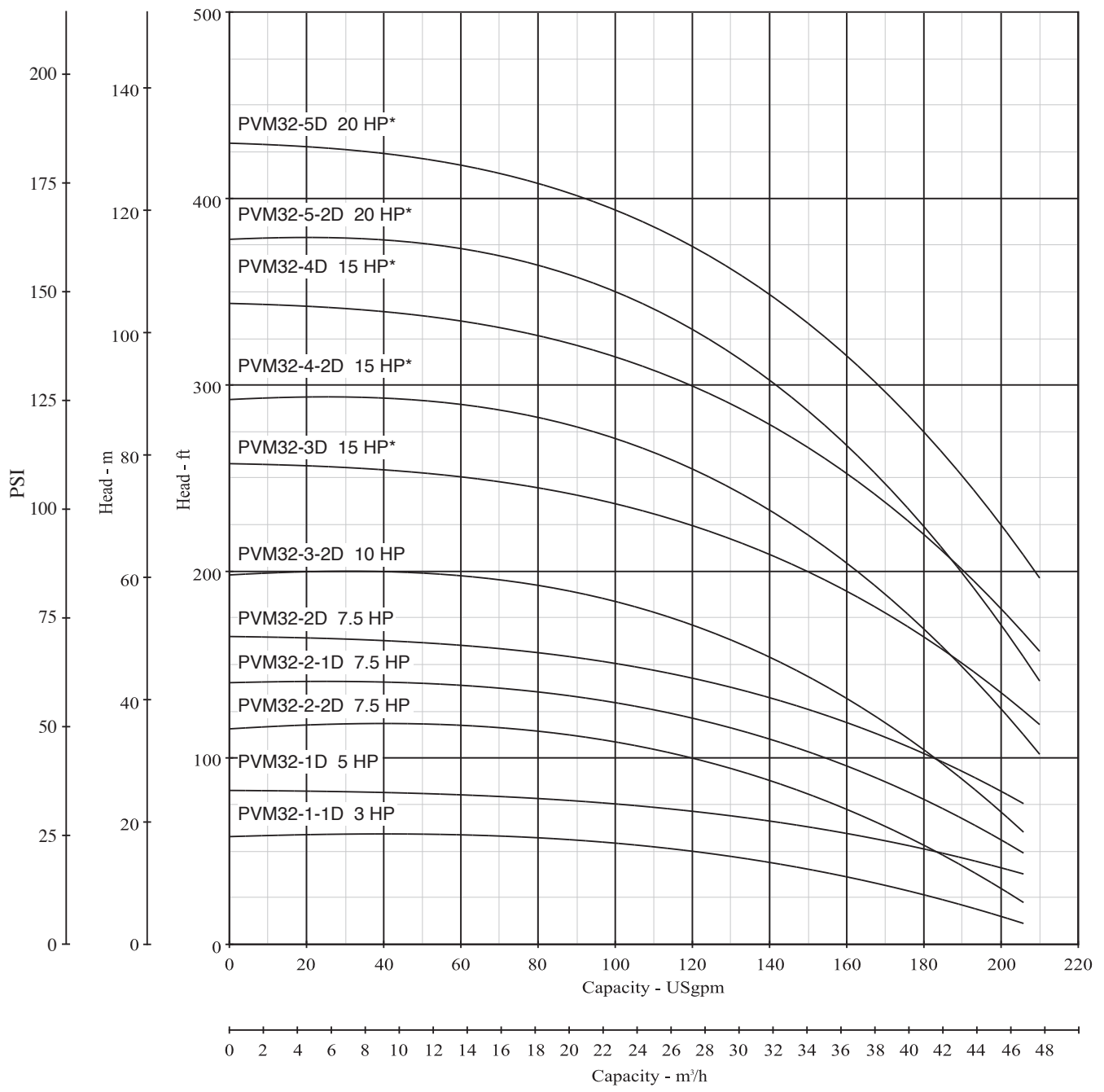

NOMINAL RPM: 3450 (*3520)

BASED ON FRESH WATER @ 68° F

MAXIMUM WORKING PRESSURE: 435 PSI

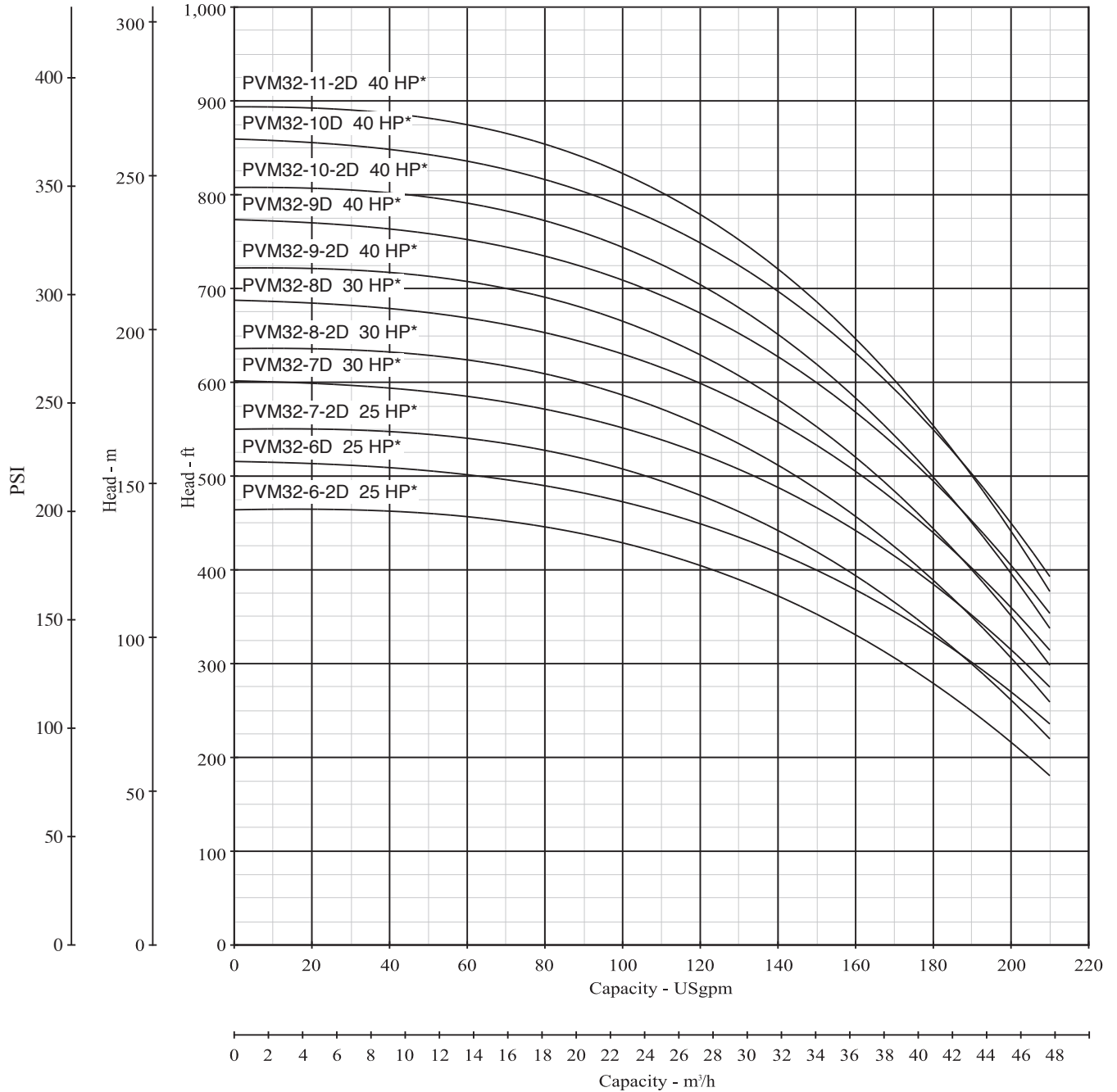

AURORA® PVM32 SERIES

SINGLE STAGE PERFORMANCE DATA

NOMINAL RPM: 3520 **BASED ON FRESH WATER @ 68° F** **MAXIMUM WORKING PRESSURE: 230 PSI**

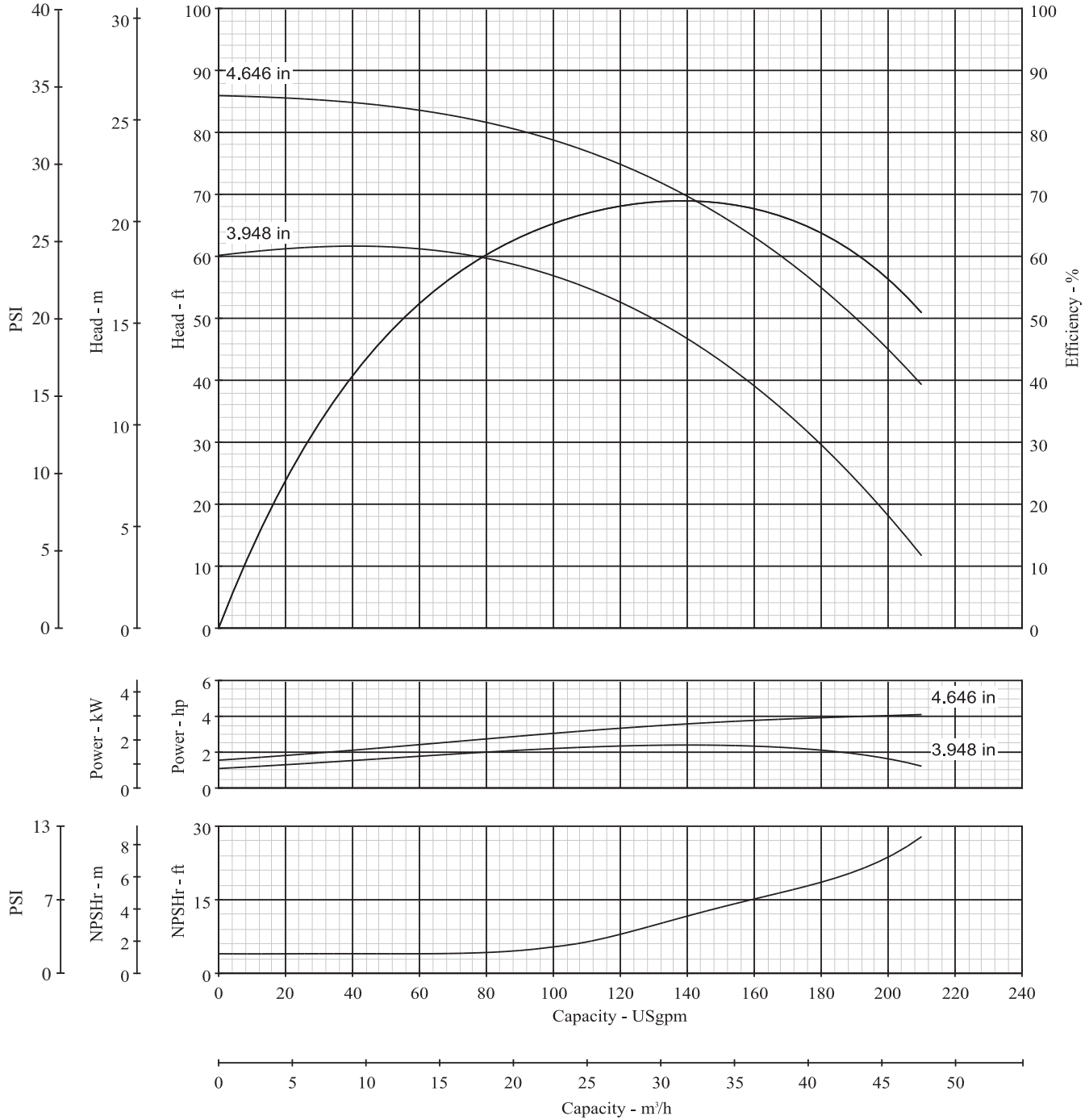

CAST IRON CONSTRUCTION

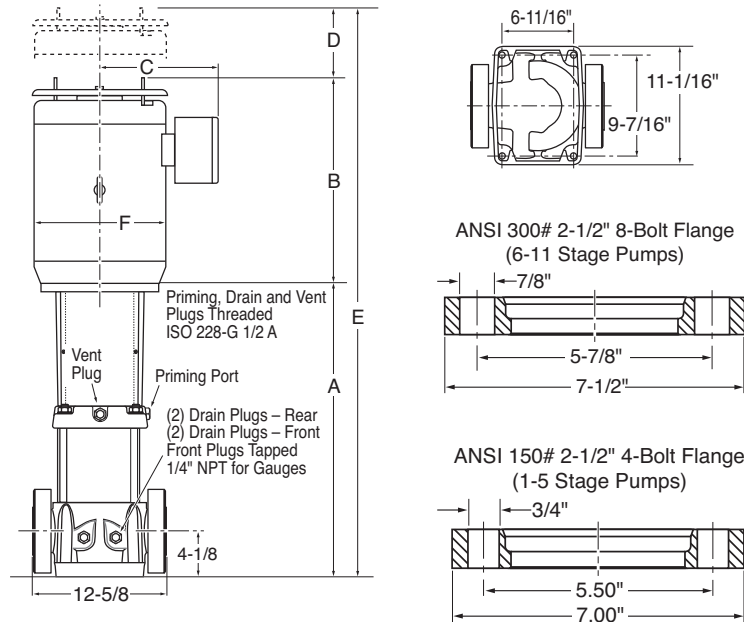

TECHNICAL INFORMATION	
MINIMUM PUMPING RATES	Up to 175° F – 15 GPM 175° F to 250° F – 35 GPM
FLOW RANGE	15 – 210 GPM
MIN. SUCTION PIPE SIZES	2-1/2" Nominal Diameter, Schedule 40 Pipe
MAX. WORKING PRESSURE	435 PSI
MAX. AMBIENT TEMP.	104° F
LIQUID TEMP. RANGE	+5° F to +250° F
MOTOR OPTIONS	TEFC or ODP Single or Three Phase For other options, consult factory.
CONSTRUCTION MATERIALS	See Page 37

Model Number	HP	Motor S.F.	ph	Volts	Frame Size	Disc. Size	Suction Size	Dimensions in Inches*						TEFC Wt. (lbs.)	ODP Wt. (lbs.)
								A	B	C	D	E	F		
PVM32-1-1D	3	1.15	1	208-230	182TCZ	2.5	2.5	22.3	13.9	7.9	2.6	38.8	10.0	186	168
PVM32-1-1D	3	1.15	3	208-230/460	182TCZ	2.5	2.5	22.3	12.6	6.9	2.6	37.5	8.6	166	163
PVM32-1D	5	1.15	1	208-230	213TCZ	2.5	2.5	22.3	13.9	7.9	2.6	38.8	10.0	220	228
PVM32-1D	5	1.15	3	208-230/460	184TCZ	2.5	2.5	22.3	12.6	6.9	2.6	37.5	8.6	181	174
PVM32-2-2D	5	1.15	1	208-230	213TCZ	2.5	2.5	27.0	13.9	7.9	2.6	43.5	10.0	236	230
PVM32-2-2D	5	1.15	3	208-230/460	184TCZ	2.5	2.5	27.0	13.9	8.1	2.6	43.5	10.3	240	240
PVM32-2-1D	7.5	1.15	1	208-230	213TCZ	2.5	2.5	27.0	13.9	7.9	2.6	43.5	10.0	236	230
PVM32-2-1D	7.5	1.15	3	208-230/460	213TCZ	2.5	2.5	27.0	13.9	8.1	2.6	43.5	10.3	240	240
PVM32-2D	7.5	1.15	1	208-230	213TCZ	2.5	2.5	27.0	13.9	7.9	2.6	43.5	10.0	236	230
PVM32-2D	7.5	1.15	3	208-230/460	213TCZ	2.5	2.5	27.0	13.9	8.1	2.6	43.5	10.3	240	240
PVM32-3-2D	10	1.15	1	208-230	215TCZ	2.5	2.5	29.8	13.9	7.9	3.1	46.8	10.0	269	254
PVM32-3-2D	10	1.15	3	208-230/460	215TCZ	2.5	2.5	29.8	14.2	8.1	3.1	47.1	10.3	266	246
PVM32-3D	15	1.15	3	208-230/460	254TCZ	2.5	2.5	29.8	20.0	9.5	4.0	53.8	12.9	357	248
PVM32-4-2D	15	1.15	3	208-230/460	254TCZ	2.5	2.5	32.5	20.0	9.5	4.0	56.5	12.9	360	251
PVM32-4D	15	1.15	3	208-230/460	254TCZ	2.5	2.5	32.5	20.0	9.5	4.0	56.5	12.9	360	251
PVM32-5-2D	20	1.15	3	230/460	254TCZ	2.5	2.5	35.3	16.9	9.2	3.8	56.0	11.5	406	351
PVM32-5D	20	1.15	3	230/460	254TCZ	2.5	2.5	35.3	16.9	9.2	3.8	56.0	11.5	406	351
PVM32-6-2D	25	1.15	3	230/460	284TCZ	2.5	2.5	38.0	20.0	9.5	3.0	61.0	13.3	425	370
PVM32-6D	25	1.15	3	230/460	284TCZ	2.5	2.5	38.0	20.0	9.5	3.0	61.0	13.3	425	370
PVM32-7-2D	25	1.15	3	230/460	284TCZ	2.5	2.5	40.8	20.0	9.5	3.0	63.8	13.3	428	373
PVM32-7D	30	1.15	3	230/460	284TCZ	2.5	2.5	40.8	23.9	13.1	3.0	67.7	15.6	441	379
PVM32-8-2D	30	1.15	3	230/460	284TCZ	2.5	2.5	43.6	23.9	13.1	3.0	70.5	15.6	444	382
PVM32-8D	30	1.15	3	230/460	284TCZ	2.5	2.5	43.6	23.9	13.1	3.0	70.5	15.6	444	382
PVM32-9-2D	40	1.15	3	230/460	284TCZ	2.5	2.5	46.3	23.2	13.1	3.0	72.5	15.6	434	583
PVM32-9D	40	1.15	3	230/460	284TCZ	2.5	2.5	46.3	23.2	13.1	3.0	72.5	15.6	434	583
PVM32-10-2D	40	1.15	3	230/460	284TCZ	2.5	2.5	49.1	23.2	13.1	3.0	75.3	15.6	436	585
PVM32-10D	40	1.15	3	230/460	284TCZ	2.5	2.5	49.1	23.2	13.1	3.0	75.3	15.6	436	585
PVM32-11-2D	40	1.15	3	230/460	284TCZ	2.5	2.5	51.8	23.2	13.1	3.0	78.0	15.6	439	588

*Measurements represent the largest number possible for each model using standard efficiency motors.

Description	Material
Shaft	AISI 431 SS
Impellers, Diffuser Chambers, Pump Sleeve Split Cones, Split Cone Nuts and Suction Interconnector	AISI 304 SS
Motor Stool	Class 30 Cast Iron
Suction / Discharge, Pump Head and Motor Couplings	80-55-06 Ductile Iron
Intermediate Bearings	Leadless Tin Bronze
Diffuser Sleeves	Graphite
Lower Shaft, Stabilizer Bearing and Bearing Ring	Tungsten Carbide
O-Rings	EPDM opt: Viton®, Buna-N
Neck Rings	Teflon®
Coupling Guard	AISI 304 SS
Staybolts, Nuts and Washers	Zinc Plated Steel
Mechanical Seal: Stationary Face Rotating Face O-Rings Upper and Lower Drivers Spring	Tungsten Carbide Tungsten Carbide EPDM opt: Viton, Buna-N AISI 304 SS or Better AISI 316 SS
Seal Carrier	UNIC 40 Epoxy Coated Steel

Permissible Operating Pressure Curves

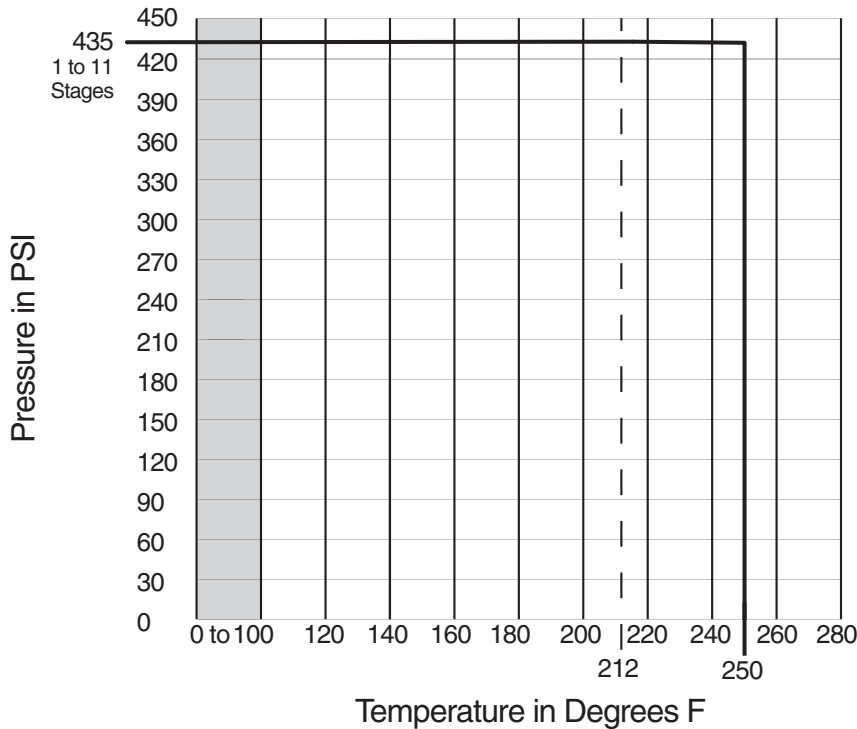

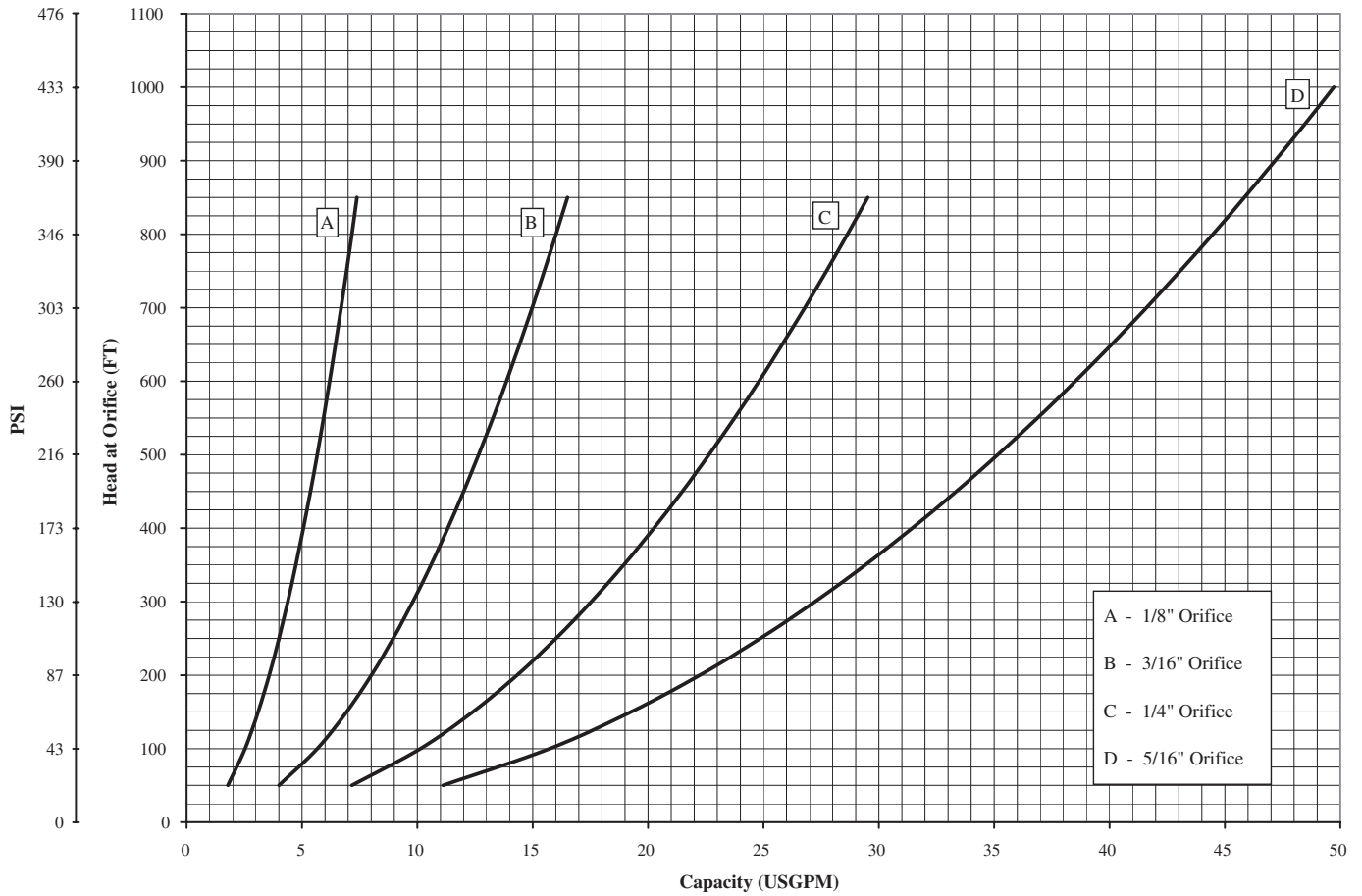

VERTICAL MULTISTAGE PERFORMANCE

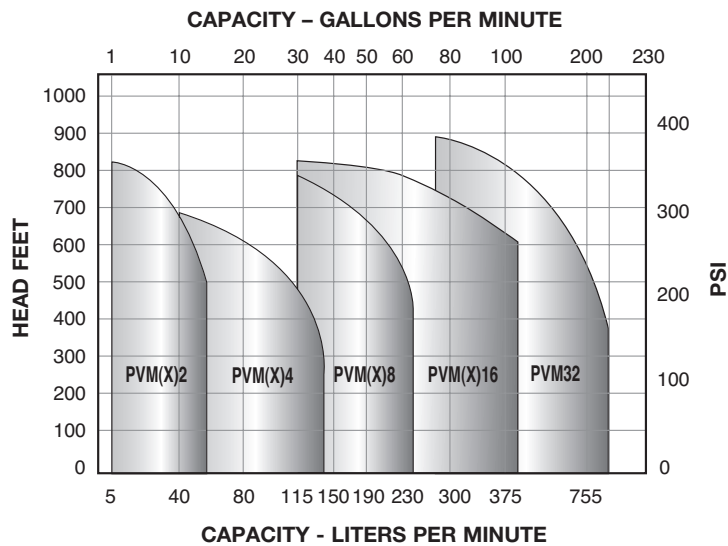

Models	Flow Series	HP Range	GPM
PVM/PVMX	2	1/2 – 5	1 – 20
PVM/PVMX	4	1/2 – 7.5	3 – 40
PVM/PVMX	8	3/4 – 15	5 – 65
PVM/PVMX	16	5 – 25	8 – 105
PVM	32	3 – 40	15 – 210



WARRANTY

Seller warrants equipment (and its component parts) of its own manufacture against defects in materials and workmanship under normal use and service for one (1) year from the date of installation or start-up, or for eighteen (18) months after the date of shipment, whichever occurs first. Seller does not warrant accessories or components that are not manufactured by Seller; however, to the extent possible, Seller agrees to assign to Buyer its rights under the original manufacturer's warranty, without recourse to Seller. Buyer must give Seller notice in writing of any alleged defect covered by this warranty (together with all identifying details, including the serial number, the type of equipment, and the date of purchase) within thirty (30) days of the discovery of such defect during the warranty period. No claim made more than 30 days after the expiration of the warranty period shall be valid. Guarantees of performance and warranties are based on the use of original equipment manufactured (OEM) replacement parts. Seller assumes no responsibility or liability if alterations, non-authorized design modifications and/or non-OEM replacement parts are incorporated. If requested by Seller, any equipment (or its component parts) must be promptly returned to Seller prior to any attempted repair, or sent to an authorized service station designated by Seller, and Buyer shall prepay all shipping expenses. Seller shall not be liable for any loss or damage to goods in transit, nor will any warranty claim be valid unless the returned goods are received intact and undamaged as a result of shipment. Repaired or replaced material returned to customer will be shipped F.O.B., Seller's factory. Seller will not give Buyer credit for parts or equipment returned to Seller, and will not accept delivery of any such parts or equipment, unless Buyer has obtained Seller's approval in writing. The warranty extends to repaired or replaced parts of Seller's manufacture for ninety (90) days or for the remainder of the original warranty period applicable to the equipment or parts being repaired or replaced, whichever is greater. This warranty applies to the repaired or replaced part and is not extended to the product or any other component of the product being repaired. Repair parts of its own manufacture sold after the original warranty period are warranted for a period of one (1) year from shipment against defects in materials and workmanship under normal use and service. This warranty applies to the replacement part only and is not extended to the product or any other component of the product being repaired. Seller may substitute new equipment or improve part(s) of any equipment judged defective without further liability. All repairs or services performed by Seller, which are not covered by this warranty, will be charged in accordance with Seller's standard prices then in effect.

THIS WARRANTY IS THE SOLE WARRANTY OF SELLER AND SELLER HEREBY EXPRESSLY DISCLAIMS AND BUYER WAIVES ALL OTHER WARRANTIES EXPRESSED, IMPLIED IN LAW OR IMPLIED IN FACT, INCLUDING ANY WARRANTIES OF MERCHANTABILITY OR FITNESS FOR A PARTICULAR PURPOSE. Seller's sole obligation under this warranty shall be, at its option, to repair or replace any equipment (or its component parts) which has a defect covered by this warranty, or to refund the purchase price of such equipment or part. Under the terms of this warranty, Seller shall not be liable for (a) consequential, collateral, special or liquidated losses or damages; (b) equipment conditions caused by normal wear and tear, abnormal conditions of use, accident, neglect, or misuse of said equipment; (c) the expense of, and loss or damage caused by, repairs or alterations made by anyone other than the Seller; (d) damage caused by abrasive materials, chemicals, scale deposits, corrosion, lightning, improper voltage, mishandling, or other similar conditions; (e) any loss, damage, or expense relating to or resulting from installation, removal or reinstallation of equipment; (f) any labor costs or charges incurred in repairing or replacing defective equipment or parts, including the cost of reinstalling parts that are repaired or replaced by Seller; (g) any expense of shipment of equipment or repaired or replacement parts; or (h) any other loss, damage or expense of any nature.

The above warranty shall not apply to any equipment which may be separately covered by any alternate or special warranties.

PERFORMANCE: In the absence of Certified Pump Performance Tests, equipment performance is not warranted or guaranteed. Performance curves and other information submitted to Buyer are approximate and no warranty or guarantee shall be deemed to arise as a result of such submittal. All testing shall be done in accordance with Seller's standard policy under Hydraulic Institute procedures.

LIABILITY LIMITATIONS: Under no circumstances shall the Seller have any liability under the Order or otherwise for liquidated damages or for collateral, consequential or special damages or for loss of profits, or for actual losses or for loss of production or progress of construction, regardless of the cause of such damages or losses. In any event, Seller's aggregate total liability under the Order or otherwise shall not exceed the contract price.

ACTS OF GOD: Seller shall in no event be liable for delays in delivery of the equipment or other failures to perform caused by fires, acts of God, strikes, labor difficulties, acts of governmental or military authorities, delays in transportation or procuring materials, or causes of any kind beyond Seller's control.

COMPLIANCE WITH LAW: Seller agrees to comply with all United States laws and regulations applicable to the manufacturing of the subject equipment. Such compliance shall include: The Fair Labor Standards Acts of 1938, as amended; Equal Employment Opportunity clauses of Executive Order 11246, as amended; Occupational Safety and Health Act of 1970 and the standards promulgated thereunder, if applicable. Since compliance with the various Federal, State, and Local laws and regulations concerning occupational health and safety, pollution or local codes are affected by the use, installation and operation of the equipment and other matters over which Seller has no control, Seller assumes no responsibility for compliance with those laws and regulations, whether by way of indemnity, warranty, or otherwise. It is incumbent upon the Buyer to specify equipment which complies with local codes and ordinances.



AURORA®

800 Airport Road
North Aurora, Illinois 60542
630-859-7000
www.aurorapump.com